

Operating Instructions

Aspect 14 Eco Boiler Stove

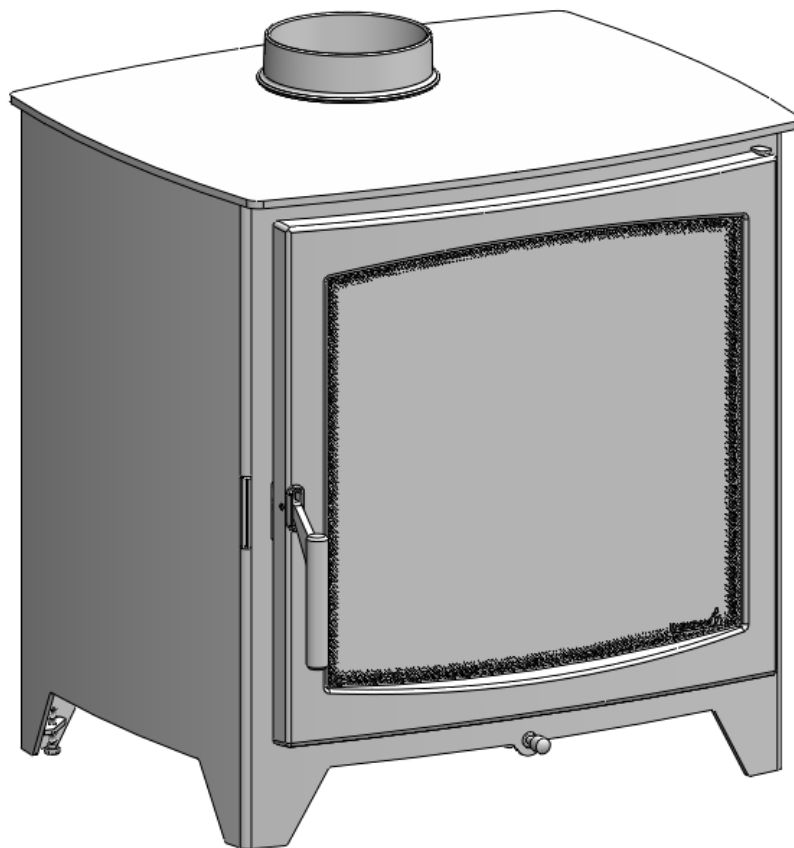

hunterstoves

GROUP



Contents

1	Introduction	3
2	SAFETY	3-4
	2.1 General	3
	2.2 Safety instructions	3-4
3	Operating Instructions	4-7
	3.1 Door operation	4
	3.2 Air control	5
	3.3 Recommended flues	5
	3.4 Lighting	6
	3.5 Ash removal	6
	3.6 Adding wood	7
	3.7 Wood weights	7
4	Care & maintenance	8-9
	4.1 Periods of prolonged non-use	8
	4.2 Cleaning glass	8
	4.3 Gaskets	8
	4.4 Stove body	8
	4.5 Chimney sweeping	8
5	Troubleshooting	10
	5.1 Difficulty to light and maintain the fire	10
	5.2 Abnormal amount of smoke	10
	5.3 Excessive soot forming on the glass	10
	5.4 Appliance body	10
6	Warranty	11-12



1 Introduction

Welcome to the Hunter Stoves family and congratulations on your purchase of this Hunter Stoves fire. This appliance has been designed and manufactured to the highest quality, and we hope it will bring you great enjoyment. The natural environment is important to us, so our stoves are manufactured to provide you with a clean and efficient burn that will keep you warm through cold winter nights. Please carefully read this user manual prior to using the appliance and keep the user and installation manuals in a safe place.

2 SAFETY

2.1 General

Please read all instructions carefully before attempting to install or operate this appliance. Failure to do so could result in a fire causing property damage, personal injury, or loss of life. Service and installation must be performed by a trained engineer. Hunter Stoves cannot accept responsibility for any fault arising from incorrect installation or operation of this product.

2.2 Safety instructions

- This appliance has been designed for domestic heating only. Please ensure that it is operated in accordance with these instructions.
- Ensure the appliance and chimney is maintained and serviced on a yearly basis.
- Do not place flammable material closer than the safe distances indicated in the installation instructions as this may cause a fire.
- It is essential that the stove has an adequate air supply for combustion and ventilation. Do not obstruct the ventilation required for the safe use of this appliance.
- Only use approved fuels.
- Do not leave children and persons who cannot judge the consequences of their actions alone with the appliance.
- Always use a fireguard in the presence of children, the elderly or the infirm. The fireguard should be manufactured in accordance with BS8423 – Fireguards for use with solid fuel appliances.
- It is a requirement to have carbon monoxide (CO) alarm that conforms to BS EN 50291 installed in the same room as the appliance. See BS EN 50292 and the alarm manufacturer's instructions for installation guidance. The use of such an alarm is not considered a substitute for regular maintenance or servicing of the appliance and flue system.



WARNING!

The appliance is a heating device. This means that all visible surfaces can become extremely hot. Avoid contact with the appliance to prevent burn injuries.



In the event of a chimney fire

- Close appliance air controls.
- Evacuate the building.
- Raise the alarm/call the fire brigade.
- Do not re-enter the building until it is deemed safe.
- Before using the appliance again ensure it has been inspected by a qualified installer and it has been confirmed safe to use.

3 Operating instructions

Properly installed and operated, this appliance will not emit fumes. Occasional fumes from de-ashing and refueling may occur. Persistent fume emission must not be tolerated. If fume emission persists, then the following immediate actions should be taken:

- Open doors and windows to ventilate the room.
- Evacuate the room.
- Let the fire go out or safely remove and dispose of fuel from the appliance.
- Check for flue/chimney blockages and clean if required.
- Do not attempt to re-light the fire until the cause of the fume emission has been identified and corrected.

3.1 Door operation

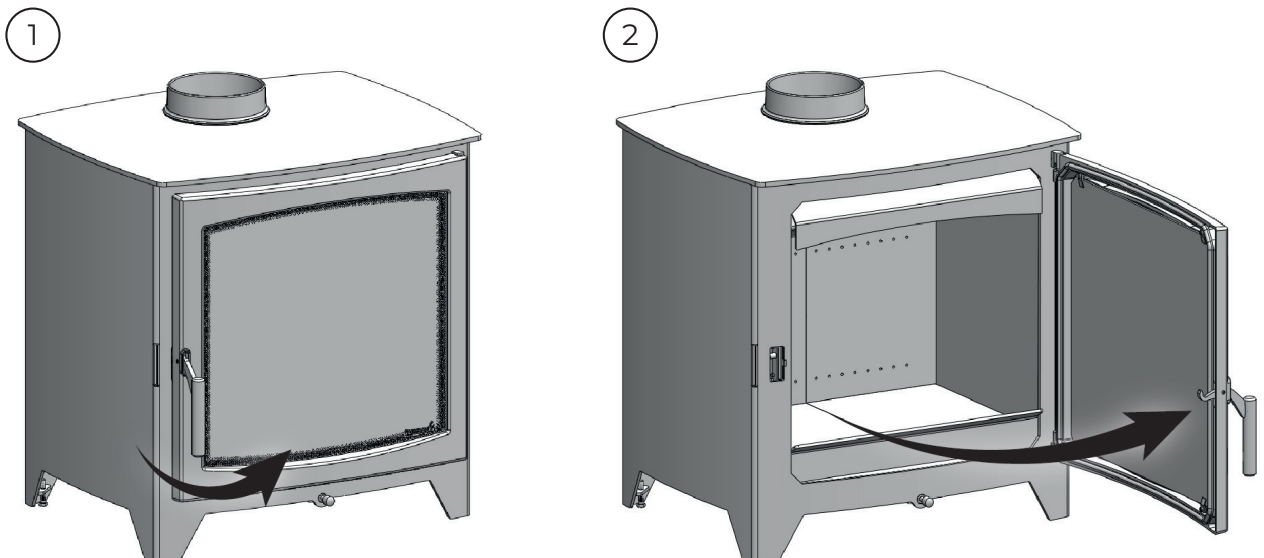

WARNING!



Use the gloves or tool provided when operating, refuelling, opening or handling internal components.



3.2 Air control

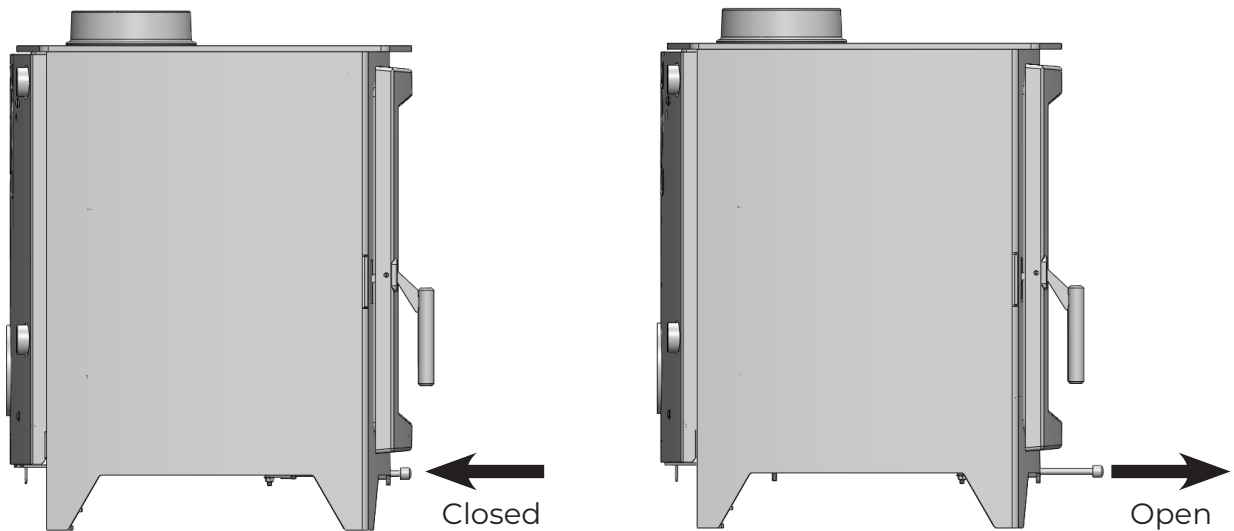

3.3 Recommended fuels

It is recommended that only wood logs with a moisture content of less than 20% should be burnt on this appliance. Burning wet or unseasoned wood will create excess smoke and tar deposits in the stove and chimney and will not produce a satisfactory heat output. To ensure the moisture content is less than 20% only buy from a woodsure certified supplier and look out for the ready to burn logo.



There are many different types of wood that can be used to fuel your appliance such as oak, ash, beech, birch, conifers, elm and fruit trees. They all have their own characteristics but are generally split into two categories, hardwoods and softwoods.

Hardwoods are higher density woods, provide a higher heat content and will generally burn longer. Softwoods are lower density woods, provide a lower heat content and will burn much quicker.

Storage

Firewood is best stored outside under a roof with the outside of the wood exposed to the air. Avoid tree cover if possible and leave a gap between the logs for air to circulate. Do not cover the logs with a plastic sheet or tarpaulin as this prevents the wood from drying. If possible bring a small amount of wood indoors for several days before use to enable any surface moisture to evaporate.

WARNING!



DO NOT BURN

- Bituminous coal, petro-coke or other petroleum based fuels.
- Painted, stained or impregnated wood such as pallets, plywood or chipboard.
- Combustible fluids.
- Plastic, textiles or other waste materials.



3.4 Lighting

Before lighting the stove check with the installer that the installation work and commissioning checks have been carried out correctly and that the chimney has been swept clean, is sound and free from any obstructions. As part of the stoves commissioning and handover, the installer should have shown you how to operate the stove correctly.

When lighting for the first time operate the appliance at a low temperature for a short period to allow the fixing cement and paint to harden. During the first few uses the appliance may emit an unpleasant odour. This is the paint curing. It is non-toxic, but for your comfort you may wish to ventilate the room by opening the doors and windows.

Hunter Stoves recommends the top down lighting method for a cleaner and more convenient start.

- Ensure the air control is in the fully open position.
- In the base of the stove, place 2 or 3 larger split and dry logs. Ensure a gap is left between the logs as this allows air movement to help the fire breathe when lit.
- Place 2 smaller logs on top at 90° to the bottom logs.
- Layer approximately six to eight pieces of kindling (finely chopped wood) on top of the logs in a crisscross pattern.
- Place 1 or 2 eco fire lighters on top of the kindling in the centre.
- Finally, place 2 to 4 thin pieces of kindling on top of the eco fire lighters.
- Close the door as soon as flames appear.
- A small amount of soot may appear on the glass during the lighting. This is perfectly normal and will go after a period of time.
- Extra logs should not be added until the logs have burnt down into a bed of glowing embers.

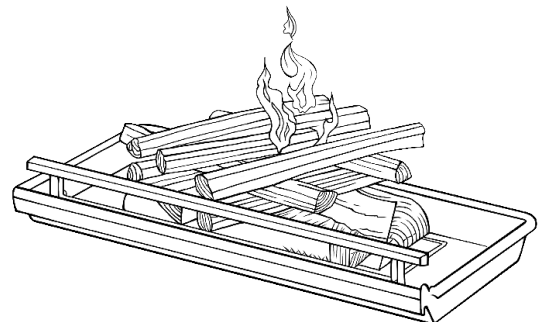
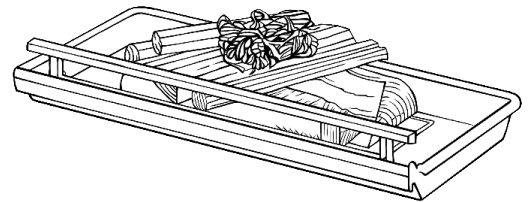

Kindling

Length - 15cm to 20cm

Diameter - 1cm to 3cm

Approximately 8-12 finely chopped pieces

Kindling is required to bridge the gap between firelighters and logs, creating the initial heat required for clean combustion. A lack of kindling may cause the fire to smoulder or potentially go out.

3.5 Ash removal

The appliance will require the ash to be removed periodically. Ensure that no embers remain when removing the ash from the appliance and take care not to damage the fire bricks during ash removal. Store the ash in a fireproof container for at least a week before disposing of them.



3.6 Adding wood

1. Only refuel when the fire has died down to embers. If there are too few embers, add some kindling to prevent excessive smoke. Ensure that the wood you are using has a moisture content of less than 20% (we recommend 12-15% to ensure an efficient burn).
2. When refuelling open all the air controls fully and the damper (if fitted).
3. Open the door slowly by releasing the handle and allow the pressure inside the stove to equalise. Opening the door too fast will cause smoke to be drawn into the room.
4. Once the pressure has equalised fully open the door and break apart the remaining char, distributing it evenly across the base of the firebox.
5. Carefully place the logs in. It is recommended you use 3 pieces of wood, placed parallel with each other as shown in the image.
6. Close the door. (All our stoves are tested as closed door appliances and should be used as such.)
7. Keep the air control in the fully open position until the logs catch fire.
8. After a few minutes once the flames are fully established, slowly close the air control for a more efficient burn.



3.7 Wood weights

It is recommended that between 2.5 and 3 kg of wood per hour is used. Please note the exact amount of wood to use is dependent on the species of wood, the moisture content, and the desired burn duration.

Please do not load the wood any higher than the maximum fill line, shown in the image, located on the side fire bricks (~160mm).

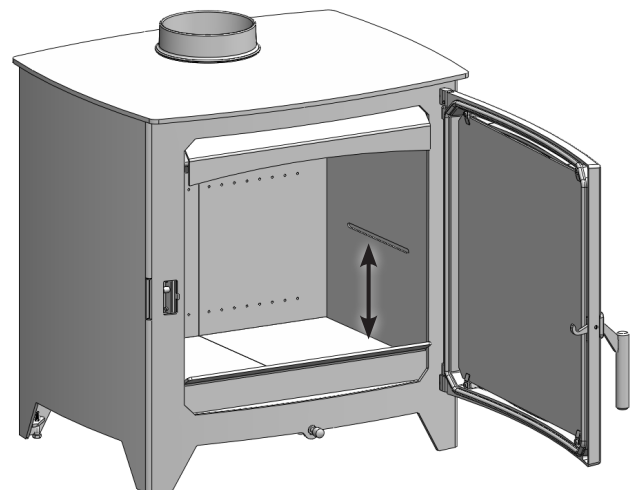

WARNING!



Avoid using an excessive amount of wood. Large fires are uneconomical and can cause damage to the stove, chimney and the surrounding walls.



4 Care & maintenance

4.1 Periods of prolonged non-use

If the stove is to be left unused for a prolonged period, then it should be given a thorough clean to remove ash and unburned fuel residues. To enable a good flow of air through the appliance to reduce condensation and subsequent damage, leave the air controls fully open.

If the appliance has been unused for a long period, such as during the spring and summer months, a competent person should check the chimney for potential obstructions before lighting the stove e.g. have the chimney swept before the start of the heating season.

4.2 Cleaning the glass

Before cleaning the glass ensure the appliance is cool. Use a dry cloth to remove any soot deposits. This is usually sufficient when cleaning the glass regularly. If more thorough cleaning is required it can be removed using an appropriate glass cleaning agent. Avoid using cleaning agents that contain abrasive, as these can scratch the glass and make subsequent cleaning more difficult.

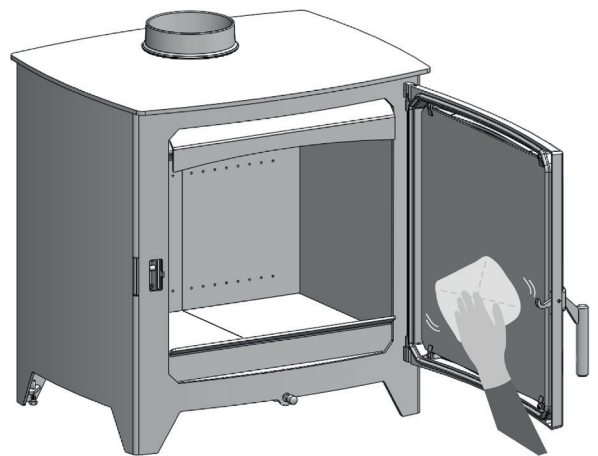

4.3 Gaskets

It is important to periodically check any gaskets to ensure the appliance is operating efficiently and safely. If any have become detached or damaged replace immediately. Replacement gaskets are available through the Hunter Stoves spares website.

4.4 Stove body

The stove body can be cleaned with a dry cloth. Damage to painted part of the appliance, such as scratches can be repaired using Hunter stoves touch up paint available online.

4.5 Chimney sweeping

It is important that the chimney, flue ways and any connecting ducts are swept at least once a year by a qualified chimney sweep. If the appliance is used continuously throughout the year more frequent sweeping is recommend.

Replacement parts can be purchased online at www.hunterstoves.co.uk



SMOKE CONTROL AREA EXEMPT

The Clean Air Act 1993 And Smoke Control Areas

Under the Clean Air Act local authorities may declare the whole or part of the district of the authority to be a smoke control area. It is an offence to emit smoke from a chimney of a building, from a furnace or from any fixed boiler if located in a designated smoke control area. It is also an offence to acquire an “unauthorised fuel” for use within a smoke control area unless it is used in an “exempt” appliance (“exempted” from the controls which generally apply in the smoke control area).

In England appliances are exempted by publication on a list by the Secretary of State in accordance with changes made to sections 20 and 21 of the Clean Air Act 1993 by section 15 of the Deregulation Act 2015. In Scotland appliances are exempted by publication on a list by Scottish Ministers under section 50 of the Regulatory Reform (Scotland) Act 2014. Similarly, In Northern Ireland appliances are exempted by publication on a list by the Department of Agriculture, Environment and Rural Affairs under Section 16 of the Environmental Better regulation Act (Northern Ireland) 2016. In Wales appliances are exempted by regulations made by Welsh Ministers.

Further information on the requirements of the Clean Air Act can be found here:
<https://www.gov.uk/smoke-control-area-rules>

Your local authority is responsible for implementing the Clean Air Act 1993 including designation and supervision of smoke control areas and you can contact them for details of Clean Air Act requirements.

The following stoves have been recommended for use in smoke control areas when burning wood logs:

- Aspect 14 Eco Boiler

Each stove must be fitted with a permanent stop provided by the Hunter Stoves to prevent full closure of the air controls. In a smoke control area, the air control stop must be fitted. If this is removed, then the stove will no longer be exempt and therefore no longer suitable for burning unauthorised fuels in a smoke control area.

Refuelling on to a low fire bed

If there is insufficient burning material in the firebed to light a new fuel charge, excessive smoke emission can occur. Refuelling must be carried out onto a sufficient quantity of glowing embers and ash that the new fuel charge will ignite in a reasonable period. If there are too few embers in the fire bed, add suitable kindling to prevent excessive smoke.

Fuel overloading

The maximum amount of fuel specified in this manual should not be exceeded, overloading can cause excess smoke.

Operation with door left open

Operation with the door open can cause excess smoke. The appliance must not be operated with the appliance door left open except as directed in the instructions.

Dampers left open

Operation with the air controls or appliance dampers open can cause excess smoke. The appliance must not be operated with air controls, appliance dampers or door left open except as directed in the instructions.



5 Troubleshooting

5.1 Difficult to light and maintain the fire

- The wood may not be dry enough. Check the moisture content of the fuel.
- The flue draught may be affected. Check the chimney is not blocked and that no nearby buildings or trees affect the wind around it.
- Air ventilation to the room may be affected. Check the rooms air vent is not blocked (if installed) and switch off any extraction fan in the house. Open a window near the appliance and try heating the flue gradually to generate a draught.
- If this is only occurring occasionally it could be due to varying weather conditions, especially the wind. An anti-down draught cowl might need to be fitted (speak to a specialist) or a flue damper may also be of help.

5.2 Abnormal amount of smoke

This can happen for a variety of reasons e.g. cold air trapped in chimney/flue. As cold air is denser, this causes smoke to be forced back down the chimney. We recommend trying to heat the chimney before lighting for example, placing a firelighter on top of the kindling. Ensure wood has a moisture content of less than 20% as this can cause excess smoke. Also check the type of wood as softwood produces a lot more smoke.

5.3 Excess soot forming on the glass

If your glass is blackening this can be due to incorrect use of air controls (see instructions). Alternatively, poor quality fuel which has a high moisture content can also be a cause. When the glass has a white shadow(or crazing) on the inside then this can be caused due to over-firing, too much primary air or a vacuum in the room.

5.4 Appliance body

Paint curing

The stove paint curing process takes place at room temperature and the surface coating is virtually free from fumes and odours. When being put into operation for the first time we would recommend that windows and doors are opened for a short time to provide ventilation.

Paint discoloured

If the surface of the appliance turns grey or the paint starts to flake or peel then this is due to an excessive temperature in the appliance. The reason for this can be too much wood or the incorrect type of fuel has been used.

Noise

When the appliance body heats up and cools down it may make some clicking noises. This is due to the large temperature differences and is not a problem with the appliance.



6 Warranty

2 Year Standard Warranty

Any appliance bought through the showroom of an authorised Hunter Stoves Group dealership will automatically be covered by our standard 2-year conditional guarantee.

However, this standard 2-year warranty can be extended to a 5 year or 10-year conditional warranty dependent on the model type (5 years - Boiler model and Gas models, 10 years - Room heater).

To qualify for this extended warranty option, you need to:

- Register your purchase online at <https://www.hunterstoves.co.uk/ProductRegistration>
- Retain your proof of purchase.

Warranty Conditions

For the Standard 2 year or extended 5/10-year warranty to be valid and to remain in force throughout the warranty period the following must have been carried out:

- The appliance must have been installed by an appropriately qualified engineer (from the Competent Person Scheme/Gas Safe) in accordance with the manufacturer's instructions and in compliance of any relevant national or local building regulations. Please visit the following links for details on the Competent Person Scheme: <https://www.gov.uk/guidance/competent-person-scheme-current-schemes-and-how-schemes-are-authorized> and Gas Safe register: <https://www.gassaferegister.co.uk/>
- The appliance will need to be registered within two months of purchase and the commissioning and installation documentation completed (these need to be kept by the end user).
- The appliance must be serviced within 12 months of the installation date for the second year of the standard warranty to be valid, and within every 12-month anniversary thereafter to maintain the validity and coverage of any extended warranty. For this purpose, the installation and user instructions, supplied with the appliance, makes a provision for receipts and annual services to be recorded. This is needed in the event of a claim during the warranty period.
- Only genuine Hunter Stoves spare parts or consumables can be used in the servicing and maintenance of the appliance during any standard or extended warranty period. These can be sourced from your authorised supplier directly or through our website spares portal. www.hunterstoves.co.uk/spares.
- Any problems or issues giving rise to any claim under the standard or extended warranty must be submitted to the authorised Hunter Stoves Group retailer from whom you originally purchased the appliance. Hunter Stoves Group will then offer appropriate support and help through your original authorised supplier to solve any issues.
- The standard or extended warranty option is not transferable. It is solely for the benefit of the original purchaser of the appliance. For this purpose, please retain the proof of purchase.



Warranty Exclusions

No warranty period is extended to naturally-wearing replaceable consumables and spare parts within the appliance. Such parts include, but are not limited to:

- Gas pilot assemblies
- Thermocouples and pilot assembly
- Ceramic log & coal 'fuel -effects'
- Batteries

Paint and Surface Coverings

The paint or surface covering of the appliance will be covered (for 2 years after installation) provided the warranty conditions are met. However, damage due to the following events will not be covered:

- Damage to the paint surface caused by the appliance being stored in a damp and cold environment is not covered under warranty. Please be aware that any moisture within the room where the stove is installed e.g. through clothes drying, can be a cause of paint issues.
- In the course of the initial firings of the appliance the paint or enamel surface may change colour. This is normal and as such is therefore not covered under warranty.
- Damaged caused by over firing/excessive temperatures, resulting in cracking, bubbling or discolouration to the paint or enamelled surface finish is not covered under warranty.

Warranty Limitations

- Damage to the appliance due to specific local conditions caused by draft or chimney defects.
- Damage resulting from installation and use where installation is not in accordance with the manufacturer's instructions or local building and/or safety regulations.
- Consequential loss to associated non-Hunter Stoves Group products is not covered under the warranty.
- Consequential loss relating to decorations, soft furnishings or other household assets is not covered under the warranty.
- Cost associated with the removal and re-installation of an appliance subject to a warranty claim.

Hunter Stoves Group total liability will only extend to the total purchase price paid for the goods in any warranty claim. Hunter Stoves Group reserve the right to replace, repair or refund to value of goods purchased.

ANY HUNTERS STOVES GROUP PRODUCT PURCHASED VIA AN INTERNET SUPPLIER, OR THROUGH AN UNAUTHORISED STOCKIST WILL ONLY BE SUPPORTED BY THE STATUTORY, 12 MONTH GUARANTEE AND WILL NOT QUALIFY FOR ANY EXTENDED 5- OR 10-YEAR WARRANTY.

The Hunter Stoves Group extended warranty option does not affect your statutory rights. The standard/extended warranty applies to purchases of Hunter Stoves within the United Kingdom and the Republic of Ireland. Purchases in all other countries are subject to the warranty conditions specified by the distributor in those markets.



hunterstoves
GROUP

Hunter Stoves, 8 Emperor Way, Exeter,
Devon, EX1 3QS
www.hunterstoves.co.uk