



# Elypse

## COAL EFFECT BALANCED FLUE GAS FIRE

### Installation and Maintenance Instructions

Hand these instructions to the user

Model No. NBFC\*\*MN for use on Natural Gas (G20) at a supply pressure of 20 mbar in G.B. / I.E.

NB : \*\* denotes trim / fret variant

## **Information Requirements for Commission Regulation (EU) 2015/1188**

<b>Model Identifier</b>	<b>NBFC**MN</b>
<b>Indirect Heating Functionality</b>	<b>No</b>
<b>Direct Heat Output</b>	<b>2.7kW</b>
<b>Indirect Heat Output</b>	<b>Not Applicable</b>
<b>Fuel</b>	<b>Natural Gas (G20)</b>
<b>NOx Emissions</b>	<b>130mg/kWh</b>
<b>Nominal Heat Output</b>	<b>2.7kW</b>
<b>Minimum Heat Output (Indicative)</b>	<b>1.3kW</b>
<b>Useful Efficiency at Nominal Heat Output</b>	<b>80.0%</b>
<b>Useful Efficiency at Minimum Heat Output (Indicative)</b>	<b>50.0%</b>
<b>Auxilliary Power Consumption at Nominal Heat Output</b>	<b>Not applicable</b>
<b>Auxilliary Power Consumption at Minimum Output</b>	<b>Not applicable</b>
<b>Auxilliary Power Consumption at Standby Mode</b>	<b>Not applicable</b>
<b>Permanent Pilot Flame Requirement</b>	<b>Not applicable</b>
<b>Type of Heat Output / Room Temperature Control</b>	<b>Two or more manual stages, no room temperature control</b>
<b>Contact Details</b>	<b>BFM Europe Ltd. Gordon Banks Drive Trentham Lakes North Stoke-on-Trent ST4 4TJ Tel : 01782 339000</b>

# CONTENTS

	<b>PAGE</b>
<b>Section 1 Information and Requirements</b>	
1.0 Appliance Information	3
1.1 Conditions of Installation	4
1.2 Fireplace surround & suitability	4
1.3 Flue Terminal Position	5
1.4 Shelf position	6
1.5 Hearths	6
<b>Section 2 Installation of Fire</b>	
2.1 Unpacking the fire	6
2.2 Fireplace opening	6-7
2.3 Preparation of the wall	8
2.4 Preparation of the flue hole	9
2.5 Preparation of the flue pipes	10
2.6 Installation of the gas supply	11-12
2.7 Securing of the firebox to the wall	12-14
2.8 Preparation for mounting the flue terminal	15
2.9 Fitting the terminal guard	16
2.10 Removal & refitting of the glass frame	16
<b>Section 3 Assembling Fuel Bed and Commissioning</b>	
3.1 Fitting the fuel bed	17-18
3.2 Lighting the appliance	19
<b>Section 4 Maintenance</b>	
4.1 Removal of the Burner Assembly	19
4.2 Removal of the Piezo Igniter	20-21
4.3 Removal of the Control Valve	21
4.4 Removal of the Pilot Assembly	21-22

**Model number NBFC\*\*MN** is manufactured by:-

BFM Europe Ltd  
Trentham Lakes  
Stoke-on-Trent  
Staffordshire  
ST4 4TJ

## SECTION 1 INFORMATION AND REQUIREMENTS

### 1.0 APPLIANCE INFORMATION

Main injector : (1 off)	Stereomatic Injector Elbow – size 60 (NG)
Pilot Type :	S.I.T.140 Series NG – size 27
Max. Gross Heat Input :	3.8 kW
Min. Gross Heat Input :	2.5 kW
Gas Rate :	0.345 m <sup>3</sup> /hr
Cold Pressure :	20.0+/-1.0 mbar (8.0 +/- 0.4 in w.g.)
Ignition :	Push-button Piezo
Electrode Spark Gap :	4.0mm
Weight (with fender) :	24.5 kg inclusive of flue pipe and terminal

**Fig 1**

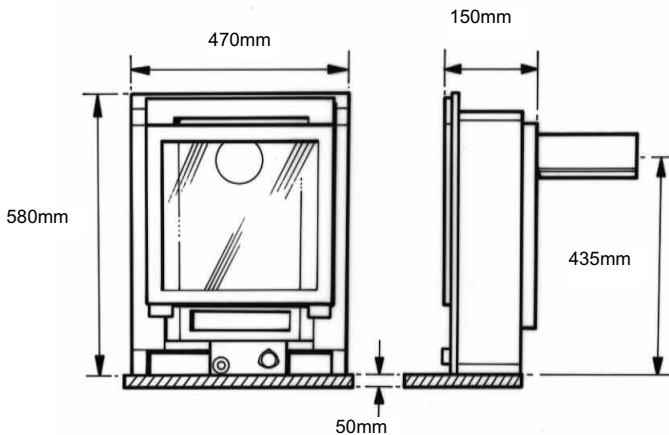

# INSTALLATION REQUIREMENTS

## Efficiency Declaration

The efficiency of this appliance has been measured as specified in BS EN 613 : 2001 and the result is 74%.

The gross calorific value of the fuel has been used for this efficiency calculation.

The test data from which it has been calculated has been certified by Advantica. The efficiency value may be used in the UK Government's Standard Assessment Procedure (SAP) for energy rating of dwellings.

## 1.1 CONDITIONS OF INSTALLATION

It is the law that all gas appliances are installed only by a GAS SAFE Registered Installer, in accordance with these installation instructions and the Gas Safety (Installation and Use) Regulations 1998 as amended. Failure to install appliances correctly could lead to prosecution. It is in your own interest and that of safety to comply with the law.

The installation must also be in accordance with all relevant parts of the Local and National Building Regulations where appropriate, the Building Regulations (Scotland Consolidation) issued by the Scottish Development Department, and all applicable requirements of the following British Standard Code of Practice.

1. B.S. 5871 Part 1 Installation of Gas Fires
2. B.S. 6891 Installation of Gas Pipework
3. B.S. 5440 Parts 1 & 2 Installation of Flues and Ventilation
4. I.S 813 : 1996 Domestic Gas Installation, issued by the National Standards Authority of Ireland.

## 1.2 FIREPLACE / SURROUND SUITABILITY

The fire must only be installed on a hearth it **must not be installed directly onto carpet or other combustible floor materials.**

The fire is suitable for fitting to non-combustible fire place surrounds and proprietary fire place surrounds with a temperature rating of at least 150<sup>o</sup>c.

**If a heating appliance is fitted directly against a wall without the use of a fire surround or fire place all combustible material must be removed from behind the trim. Soft wall coverings such as blown vinyl, wall paper etc. could be affected by the rising hot air and scorching and/or discoloration may result. Due consideration should be made to this when installing or decorating.**

### 1.3 FLUE TERMINAL POSITION

The minimum acceptable dimensions from the flue terminal to obstructions and ventilation openings are shown below and listed in the table. It is important that the position of the flue allows the free passage of air across it at all times. The minimum acceptable space from the flue terminal to obstructions and ventilation openings are specified below (Fig. 2)

Fig. 2

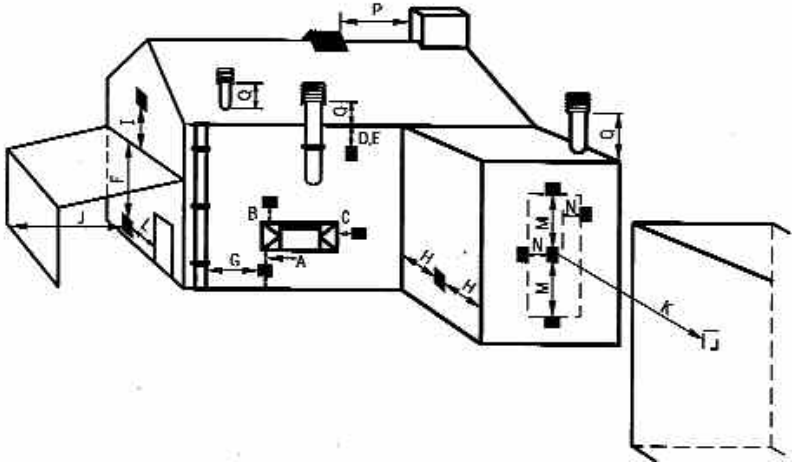

DIMENSION	TERMINAL POSITION	MINIMUM DIMENSION
A	Directly below an opening, air brick, opening window	300mm (12in)
B	Above an opening, air brick, opening window	300mm (12in)
C	Horizontally to an opening, air brick, opening window etc.	
D	Below gutters, soil pipes or drain pipes	300mm (12in)
E	Below eaves	300mm (12in)
F	Below balconies or car port roof	600mm (12in)
G	From a vertical drain pipe or soil pipe	300mm (12in)
H	From an internal or external corner	600mm (24in)
I	Above ground roof or balcony level	300mm (12in)
J	From a surface facing the terminal	600mm (24in)
K	From a terminal facing the terminal	600mm (24in)
L	From an opening in the car port	1200m (48in)
M	Vertically from a terminal on the same wall	1500mm(59in)
N	Horizontally from a terminal on the same Wall	300mm (12in)
O	NOT APPLICABLE	N/A
P	NOT APPLICABLE	N/A
Q	NOT APPLICABLE	N/A

## 1.4 SHELF POSITION

The fire may be fitted below a combustible shelf providing there is a minimum distance of 200mm above the top of the fire and the shelf does not project more than 150mm. If the shelf overhangs more than 150mm the distance between the fire and the shelf must be increased by 15mm for every 25mm of additional overhang over 150mm.

## 1.5 HEARTHES

This appliance does not require the fitting of a hearth, but we do recommend that a hearth of minimum width 760mm and minimum projection forwards of 125mm is used. This recommended hearth can be manufactured from combustible or non-combustible material.

# SECTION 2 INSTALLATION OF FIRE

## 2.1 UNPACKING THE FIRE

Carefully lift the fire out of the carton. Remove the loose item packaging carefully from the the pack. Check the contents as listed :-

**IMPORTANT : THE CARDBOARD FITMENT THAT IS AT THE TOP OF THE CONVECTION APERTURE SHOULD NOT BE REMOVED UNTIL THE APPLIANCE IS FULLY INSTALLED AND READY TO BE LIT.**

**DO NOT UNDER ANY CIRCUMSTANCES USE THIS APPLIANCE IF THE GLASS PANEL IS BROKEN OR NOT SECURELY FIXED TO THE FIREBOX.**

### Packing Check List

1 off	Fire box & foam seal / burner assembly	
1 off	Trim (if supplied by Verine)	
1 off	Boxed ceramic one piece fuel bed	
1 off	Flue Terminal unit	
1 off	Loose Items pack – containing:-	Cable fixing kit, Section of Foil Tape 10 off rawplugs, 12 off No.8 x 10mm screws 1 off 6mm Allen Key 1 off Right Hand Supply Pipe 10 off No.12 x 40mm fixing screws 1 off heat deflector

## 2.2 FIRE PLACE OPENING

The front opening of the fire place must be between 410 and 420mm wide, and between 550 and 560mm high. If the opening exceeds these dimensions then a surround must be constructed from suitable non-combustible material to produce a suitable sized opening. Any surround must be suitably sealed to the fire place to prevent leakage. See fig. 3 below

**Fig.3**

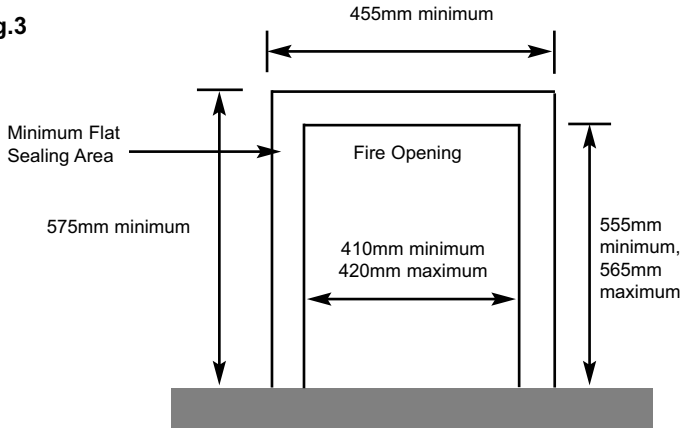

A min / max sized opening with a flat rear face between the fire opening and flue outlet terminal is shown below. (fig 4).

**Fig.4**

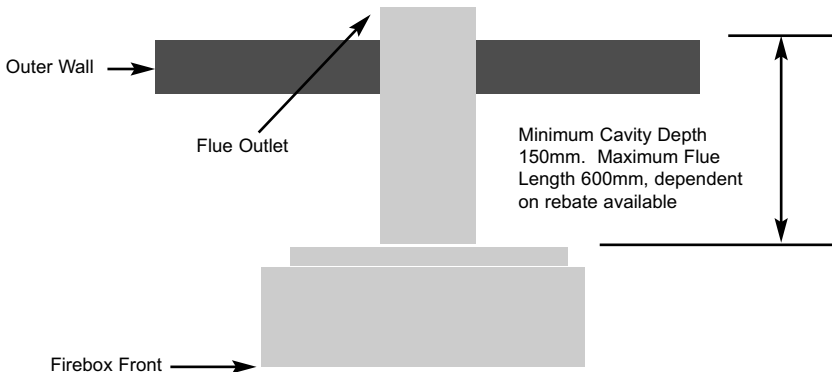



**NOTE : WHEN MEASURING LENGTH BETWEEN FIREBOX AND THE OUTER WALL TAKE INTO ACCOUNT THE DISTANCE BETWEEN THE BACK OF THE FIREBOX AND THE INNER WALL AS THIS WILL VARY BETWEEN INSTALLATIONS, DEPENDENT UPON THE REBATE AVAILABLE. (DIMENSION “X” BELOW - FIG. 5).**

**Fig. 5**

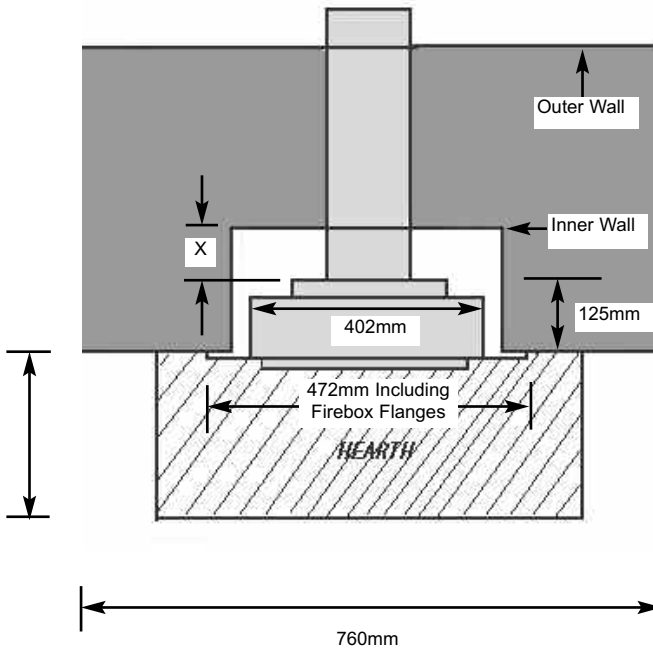

The appliance must be fitted into a fireplace or false chimney constructed of non-combustible materials, minimum width 402mm, minimum rebate 50mm (with optional black 3" spacer fitted), or 125mm without black spacer fitted.

### **2.3 PREPARATION OF THE WALL**

The appliance and flue pipes must be installed at right angles to the mounting wall. The appliance itself should be installed vertically against a flat wall. Where an uneven wall surface is found, appropriate action should be taken to ensure that the appliance is not stressed or does not distort when installed.

Ensure that the floor surface onto which the appliance is mounted onto is flat.

The minimum height from the floor to the centre of the flue is shown on fig. 6 over-page.

**Fig. 6**

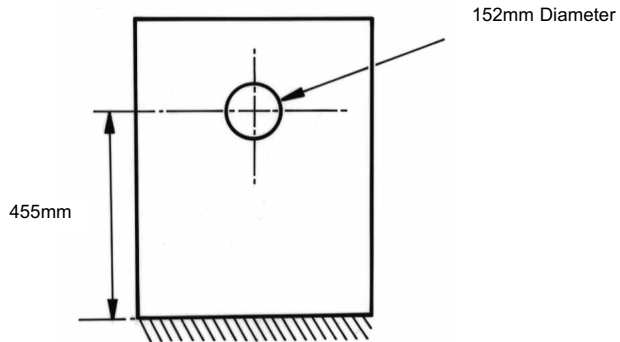

## **2.4 PREPARATION OF THE FLUE HOLE**

- a) Mark the position of the centre of the flue on the inner wall.
- b) Cut hole for outer flue pipe. There are two possible methods to achieve this, either core drill or via hammer and chisel.
- c) To core drill, proceed as follows :-

Drill a pilot hole through the wall, in position as specified in figure 5.

Using a 6" core drill, drill the flue hole.

To Hammer and chisel, proceed as follows :-

Mark the position of the centre of the flue pipe as specified in figure 5.

Mark the position of the hole around this point.

Chisel out the area as marked on the wall.

We then recommend that a cardboard cylinder is placed around the flue pipe and inserted in the chiselled out hole whilst making good.

**NOTE :- If the appliance is to be installed into a building under construction, it is recommended that a non-corrosive metal tube of 6" diameter be inserted into the position of the hole as specified on page 5.**

## 2.5 PREPARATION OF THE FLUE PIPES

- a) Place the firebox into the fire opening with the spacer (if required) fitted and the fire surround correctly secured in the final position. From the outside of the house measure from the face of the outside wall to the rear panel of the firebox through the flue hole. This dimension is shown below as **dimension A**, and cut the outer flue pipe (143mm diameter) to Dimension "A"

**Fig. 7**

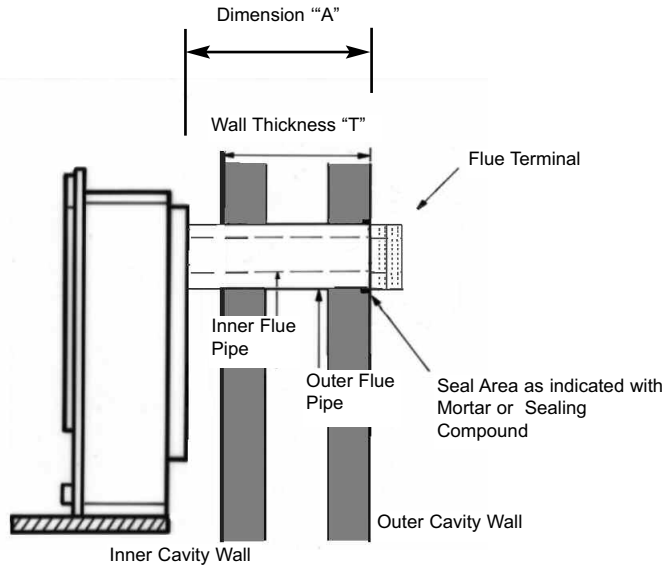

- b) For the inner flue pipe, (87.5mm diameter) add an additional 25mm to dimension "A" and cut the inner flue pipe squarely to length.

**IMPORTANT : DO NOT CUT FLANGED ENDS OF FLUE PIPE & ENSURE THE PIPES ARE CUT SQUARELY.**

- c) Using the screws and gaskets provided, fit both inner and outer flue pipes to the firebox. (See Fig. 8 overpage).
- d) Using mortar or sealing compound, seal the outer flue pipe to the outside surface of the wall, (See Fig. 7 for position of mortar).

**Fig. 8**

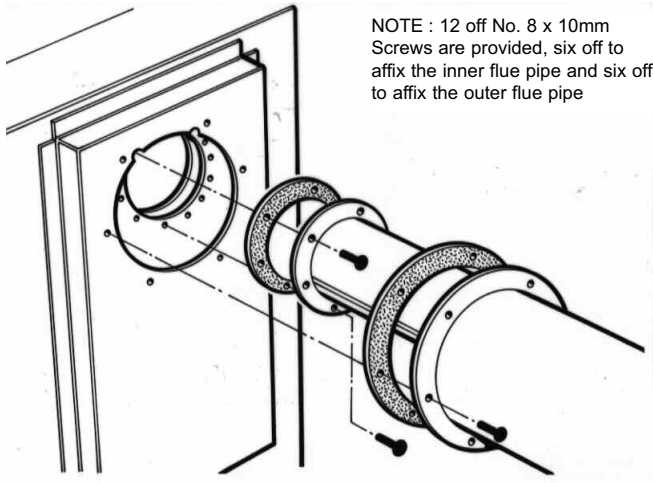

## **2.6 INSTALLATION OF THE GAS SUPPLY**

Before installing the firebox, decide from which side or if a rear connection to the gas supply is required. For R/H entry a purpose shaped gas supply pipe is supplied.

Plan the pipe run to enter the firebox from the left, right or rear and connect to the inlet elbow. See below :-

- a) If concealed pipe work is required plan the pipe run to enter the fire box through one of the openings in the sides of the fire box and connect to the inlet elbow. See **fig. 9** overpage for a suggested concealed pipe layout.

**Fig 9. (without optional 3" black spacer).**

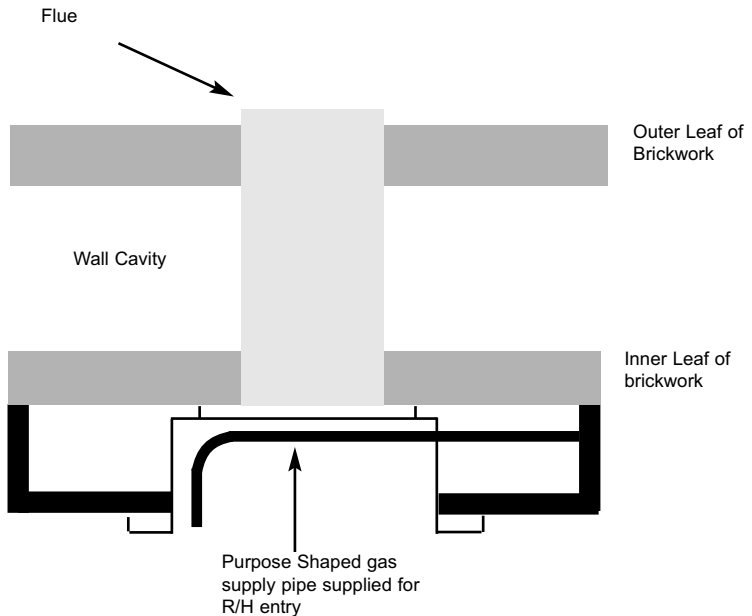

**Note : Before breaking into the gas supply a pressure drop test should be carried out to establish that the existing pipework is sound. Always block the unused entry points into the firebox with the section of foil tape as supplied.**

## **2.7 SECURING OF FIREBOX TO THE WALL**

Dependent upon if the standard firebox fixing flange or if the appliance is fitted with the black 3" spacer option, there is a choice of methods of fixing the firebox that are provided to enable the installer to deal with any type of installation. The preferred method of fixing the appliance is the cable fixing method, which is described in detail in the following section.

If the standard firebox fixing flange is to be used, the firebox may be secured using the cable method, but in installations where the cable method is not suitable, e.g. insufficient space behind the firebox, or loose masonry, the firebox can be fitted directly to either the front of the fireplace via the flange with the four off screws provided. The firebox will require sealing to the fireplace however.

To secure the fire using the preferred cable method, proceed as follows :-

- a) Mark out and drill 3 off No 14 6mm holes in the rear face of the fire opening in the positions as shown on fig. 10 below.

**Fig. 10**

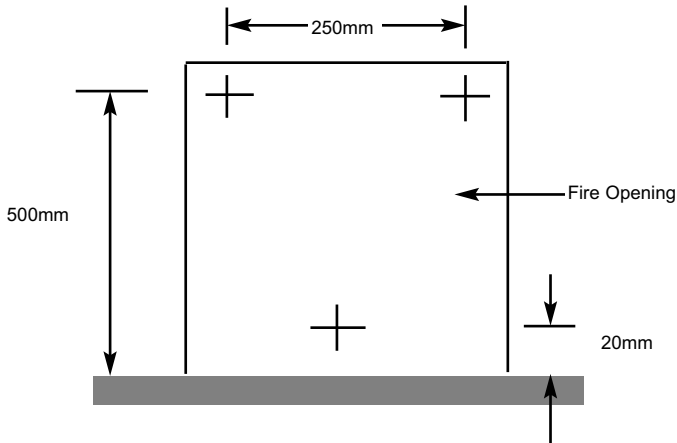

- b) Fit the wall plugs provided and screw the fixing eyes securely into the rear of the fire opening.
- c) Uncoil the two fire fixing cables and thread one end of the each of the cables through the rear of the fire box, and through each fixing eye at the top. Thread both cables through the fixing eye at the bottom.
- d) Thread the cables through the rear of the firebox, insert the flue pipes through the hole in the rear of the wall and offer the firebox up to the fireplace.
- e) Thread the cables through the bracket which is situated on the base.
- f) Thread a tensioning screw over both of the cables and ensure that the tensioning nut is screwed fully up against the hexagon shoulder of the tensioning screw (this provides maximum travel for the tensioning nut.
- g) Fit a screwed nipple on to each of the cables and pull hand tight up against the tensioning screw, then secure each nipple with a flat bladed screwdriver. See fig 11 overpage.

Fig. 11

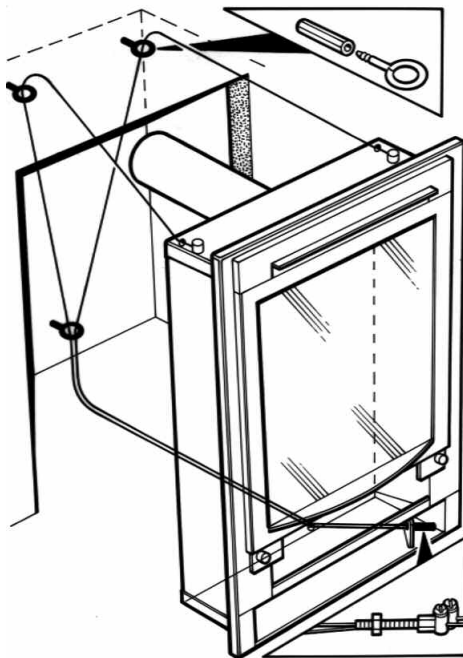

- h) Before making the final gas connection, thoroughly purge the gas supply pipework to remove all foreign matter, otherwise serious damage may be caused to the gas control valve on the fire. Failure to purge the gas supply will invalidate the guarantee.
- i) The gas connection should be made to the appliance inlet elbow to using 8mm rigid tubing.
- j) Remove the pressure test point screw from the inlet elbow and fit a manometer.
- k) Turn on the main gas supply and carry out a gas tightness test.
- l) Depress the control knob and turn anti-clockwise to the position marked pilot. Hold in the control knob for a few seconds to purge the pipe work then press the igniter button. The burner should light, continue to hold the control knob for a few seconds then turn to the full-on position.
- m) Check that the gas pressure is **20.0 mbar (+/- 1.0mbar) 8.0 in w.g.(+/- 0.4 in w.g.)**
- n) Turn off the fire, remove the manometer and refit the pressure test point screw. Check the pressure test point screw for gas tightness with the appliance turned on using a suitable leak detection fluid or detector.

## 2.8 PREPARATION FOR MOUNTING THE FLUE TERMINAL

- a) Position the flue terminal over the inner and outer flue pipes as shown on fig. 12 below, checking that the outer pipe has the seam flange at the bottom and the inner pipe has the seam flange at the top.

Fig. 12



- b) Having positioned the terminal so that it is square to the wall, mark the position of the mounting bracket holes on the outer wall, using the terminal as a template. Remove the flue terminal and drill the 2 off holes 6mm diameter into the wall. Insert the raw plugs Replace the terminal onto the flue pipe and secure using the No.12 x 40mm screws provided. See fig. 13

Fig. 13



**NOTE :** In England & Wales, the building regulations require that a terminal guard should be fitted if the terminal could come into contact with people near the building or be subject to damage. BFM Europe also recommend the fitting of a flue terminal guard where regulations do not demand that it be fitted. A suitable flue terminal guard is supplied with the appliance.



## 2.9 FITTING THE TERMINAL GUARD

With the flue terminal in position, place the terminal guard over the top of the flue terminal and mark the position of the holes on the outer wall. Remove the terminal guard and drill the 4 off 6 mm holes. Insert the raw plugs into the drilled holes, replace the terminal guard over the top of the flue terminal and attach to the wall using the No.12 x 40mm screws provided with the terminal guard. See Fig. 14 below.

**Fig. 14**



## 2.10 REMOVING & REFITTING OF THE GLASS FRAME.

**Fig. 15**

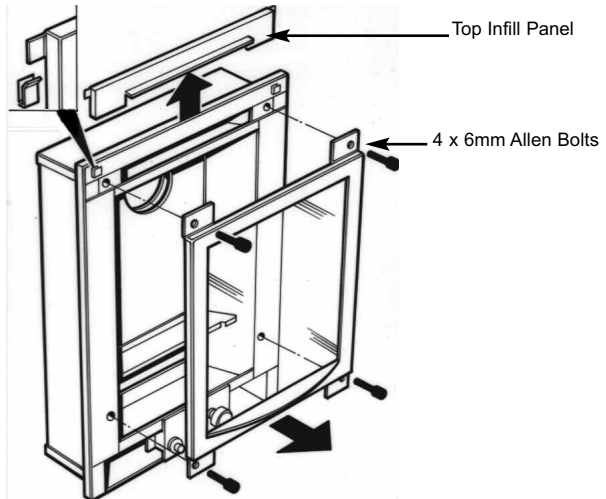

## 2.10 REMOVING & REFITTING OF THE GLASS FRAME (Continued)

- a) Remove the 2 screws which hold the pilot shield in place. (see fig. 15)
- b) Remove the top infill panel by sliding it upwards out of the clips.
- c) With the allen key provided remove the 4 allen bolts, loosening each one a small amount at a time to prevent stressing the glass panel, then lift the glass frame clear.
- d) Assemble ceramic fuel-bed and coals as shown in section three.
- e) Refit the glass panel to the fire in reverse order, again tightening each allen bolt a small amount at a time to prevent stressing the glass panel.
- f) Fit the allen key to the bracket which is situated at the bottom left hand corner of the firebox, and advise the customer of the position of the allen key.

**NOTE :** Always ensure that a consistent seal between the combustion chamber and the glass frame is achieved.

## SECTION 3 ASSEMBLING FUEL BED AND COMMISSIONING

### 3.1 FITTING THE FUELBED

**NOTE :** The position of the fuel-bed components are critical to the performance of the product. Therefore please ensure that the fuel-bed components are positioned as described in the following section prior to requesting a service call due to soot build up, poor flame pattern etc.

- a) Place the fuel-bed centrally onto the fuel-bed support. Ensure that the fuel-bed is located centrally in the firebox, and that the front outside face of the left and right hand fuel-bed legs are touching the stainless steel fibre support trims. See Fig. 16

Fig. 16



- b) Fit the heat deflector plate onto the stainless steel fibre support trims, as shown below (fig. 17 & 18)

**Fig. 17**

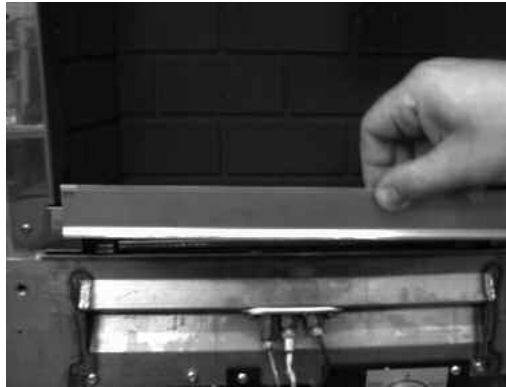

**Fig. 18**



To ensure that the release of fibres from these R.C.F (Refractory Ceramic Fibre) articles is kept to a minimum, during installation and servicing we recommend that you use a HEPA filtered vacuum to remove any dust accumulated in and around the appliance before and after working on the appliance. When replacing these articles we recommend that the replaced items are not broken up, but are sealed within heavy duty polythene bags, clearly labelled as “RCF waste”. RCF waste is classed as a “stable”, non reactive hazardous waste and may be disposed of at a landfill licensed to accept such waste. Protective clothing is not required when handling these articles, but we recommend you follow the normal hygiene rules of not smoking, eating or drinking in the work area, and always wash your hands before eating or drinking.

Refit the glass frame as detailed in section 2.10, then light the appliance as detailed in section 3.2.

### **3.2 LIGHTING THE APPLIANCE**

**IMPORTANT : IF THE BURNER IS EXTINGUISHED FOR ANY REASON YOU MUST ENSURE THAT YOU WAIT A FULL FIVE MINUTES BEFORE ATTEMPTING TO RE-LIGHT THE FIRE.**

- a) Turn on the gas restrictor at the inlet fitting.
- b) Depress the control knob and turn anti-clockwise to the position marked pilot. Hold in the control knob for a few seconds to purge the pipe work.
- c) Continue to hold-in the control knob and press the igniter button. If the burner does not light, continue to press the igniter button until ignition occurs. Continue to hold the control knob for 5-10 seconds to allow thermocouple to heat up, if the pilot goes out when the control knob is released, repeat the lighting sequence.
- d) Turn the control knob in the anti-clockwise direction to the high position and the main burner will light.
- e) Turn the control knob clockwise to the low position and the gas input will be reduced to the minimum setting.
- f) Slightly depress the control knob and turn to the pilot position, the main burner will go out but the pilot will remain lit.
- g) Slightly depress the control knob and turn to the off position, the pilot will now be extinguished.
- h) After ensuring that the fire is safe to use it should be left on high position to fully warm up. During this time a slight odour may be noticed, this is due to the “newness” of the fire and will soon disappear. Finally, hand the Installation and Maintenance Instructions and the users Instructions over to the customer and explain the operation of the fire.

**WHEN TURNING THE FIRE “OFF” PLEASE ENSURE THAT THE CONTROL VALVE IS TURNED TO THE “OFF” POSITION AND THE PILOT FLAME IS EXTINGUISHED. DO NOT LEAVE THE PILOT FLAME ONLY LIT.**

**NOTE : THIS APPLIANCE IS DESIGNED TO WORK SAFELY AND EFFECTIVELY DURING ADVERSE WEATHER CONDITIONS. HOWEVER, DURING SUCH TIMES FLAME DISTURBANCE MAY BE NOTICED. THIS IS NORMAL AND DOES NOT EFFECT OR IMPAIR THE SAFETY OF THE APPLIANCE.**

## **SECTION 4 MAINTENANCE**

### **Servicing Notes**

**Servicing should be carried out annually by a competent person such as a GAS SAFE registered engineer. It is a condition of Verine Fires guarantee schemes that this is carried out by a competent person i.e a GAS SAFE registered Engineer in accordance with these servicing notes**

The condition of the coals should be checked and **if necessary the whole set should be replaced with a genuine replacement set.**

The burner assembly is designed to be removed as a complete unit for ease of access. **After any servicing work a gas tightness check must always be carried out.**

#### **4.1 Removing the burner assembly from the fire.**

- 4.1.1 Remove Ash-pan, Fret assembly & Trim from the front of the fire.
- 4.1.2 Isolate the gas supply, remove the glass frame as shown on page 17, then remove the 2 off fixing screws which hold the pilot shield in place.
- 4.1.3 Loosen the pilot pipe, disconnect the ignition lead from the electrode and disconnect the thermocouple from the pilot assembly.
- 4.1.4 Remove the 12 off fixing screws which hold the pilot mounting panel & control panel in place.
- 4.1.5 Lift the pilot panel upwards and away from the pilot pipe, taking care not to damage or misplace the pilot injector, which is contained within the pilot body.
- 4.1.6 Loosen the burner pipe, which is situated below the burner to the left-hand-side, from the bulkhead fitting.
- 4.1.7 Remove the 4 off fixing screws which attach the burner to the firebox via fixing brackets.

#### **4.2 Removing the Piezo Igniter**

- 4.2.1 Remove Ashpan, Fret assembly & Trim from the front of the fire.
- 4.2.2 Isolate the gas supply, remove the glass frame, then remove the 2 off fixing screws which hold the pilot shield in place.
- 4.2.3 Disconnect the pipe to the bulkhead fitting, which is located to the left hand side of the convection air aperture.

- 4.2.4 Loosen the pilot pipe, disconnect the ignition lead from the electrode and disconnect the thermocouple from the pilot assembly.
- 4.2.5 Remove the 4 off fixing screws from the control panel.
- 4.2.6 Slide the control panel and gas train forwards, to the left.
- 4.2.7 Disconnect the ignition lead from the piezo and unscrew the retaining nut on the rear of the control panel. Withdraw the piezo from the front of the control panel. Re-assemble in reverse order and carry out a gas soundness test.

### **4.3 Removing the Control Valve from the fire.**

- 4.3.1 Remove Ash-pan, Fret assembly & Trim from the front of the fire.
- 4.3.2 Isolate the gas supply, remove the glass frame, then remove the 2 off fixing screws which hold the pilot shield in place.
- 4.3.3 Disconnect the pipe to the bulkhead fitting, which is located to the left hand side of the convection air aperture.
- 4.3.4 Loosen the pilot pipe, disconnect the ignition lead from the electrode and disconnect the thermocouple from the pilot assembly.
- 4.3.5 Remove the 2 off fixing screws from the base of the control panel.
- 4.3.6 Slide the control panel and gas train forwards, to the left.
- 4.3.7 Loosen and remove the three gas pipe retaining nuts from the control valve and release the ends of the gas pipes from the control valve body. Loosen and remove the thermocouple securing nut from the end of the control tap.
- 4.3.8 Unscrew the control valve locknut from the front of the control panel and remove the control valve. We do not recommend re-greasing or servicing of control valves. Defective valves should be replaced with a genuine replacement of the correct type.
- 4.3.9 To refit a control tap, re-assemble in the reverse order noting that the control tap locates on a flat in the control panel. Carry out a gas tightness test after re-assembly.

### **4.4 Removing the Pilot Assembly**

- 4.4.1 Remove Ash-pan, Fret assembly & Trim from the front of the fire.
- 4.4.2 Isolate the gas supply, remove the glass frame as shown on page 17, then remove the 2 off fixing screws which hold the pilot shield in place.

- 4.4.3 Loosen the pilot pipe, disconnect the ignition lead from the electrode, and remove the thermocouple from the pilot body.
- 4.4.4 Remove the two fixing screws which secure the pilot assembly to the pilot panel.
- 4.4.5 Remove the pilot assembly.
- 4.4.6 Re-assemble with an new pilot assembly, and gasket, ensuring than an even seal around the pilot assembly is obtained. Carry out a gas test after re-assembly.

**Due to our policy of continual improvement and development the exact accuracy of illustrations and descriptions contained in this book cannot be guaranteed**

### **PARTS SHORTLIST**

Replacement of parts must be carried out by a competent person such as a GAS SAFE registered gas installer. The part numbers of the replaceable parts are as follows, these are available from your local Verine Stockist, whose details may be found on the BFM Europe website, address as shown on the back page of this book.

Gas Valve	SP10689
Piezo Igniter	B-1320
Ignition Wire	B-14340
Fuelbed	70-47800

**Part No. B-1004437**  
**Issue 2**



At the heart of your home

BFM Europe Ltd.  
Trentham Lakes  
Stoke-on-Trent  
Staffordshire  
ST4 4TJ

[www.bfm-europe.com](http://www.bfm-europe.com)

**Telephone - General Enquiries :** (01782) 339000  
**Telephone - Service :** (01782) 339008