

THE
GALLERY
COLLECTION

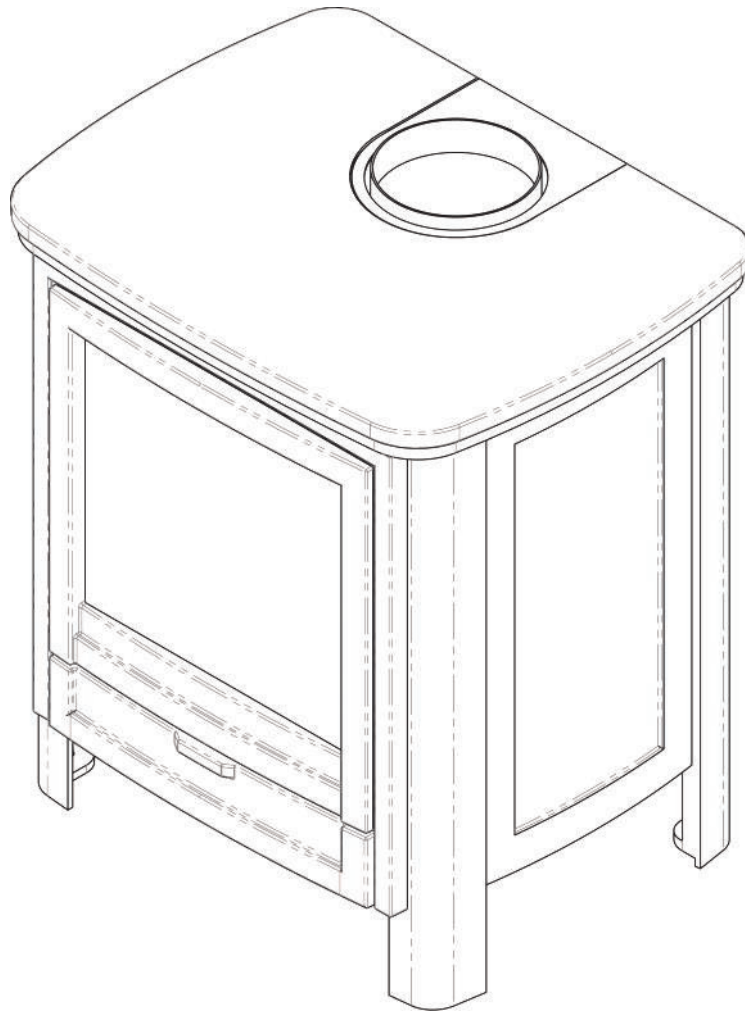

CONVENTIONAL FLUE

INSTALLATION INSTRUCTIONS

DARWIN

CONVENTIONAL FLUE GAS STOVE

CONTENTS

1.0 USER INSTRUCTIONS - REMOTE CONTROL	Page 3
1.1 General	
1.2 Manual transmitter	
1.3 Screen setup	
1.4 Setting the time	
1.5 Setting the timer: P1 and P2 (thermostat version only)	
1.6 Igniting the flame (remote control)	
1.7 Possible error messages	
1.8 Setting the flame height / extinguishing the flame	
1.9 Switching the unit off	
1.10 Inserting and replacing batteries	
2.0 USER INSTRUCTIONS - MANUAL CONTROL	Page 6
2.1 Igniting the fire	
2.2 Extinguishing the fire	
2.3 Switching the unit off	
3.0 INSTALLATION INSTRUCTIONS	Page 7
3.1 General instructions	
3.2 Chimney preparation	
4.0 POSITIONING THE APPLIANCE	Page 8
4.1 Installation of the flue liner	
4.2 Connecting the gas lines	
4.3 Preparation and installation	
4.4 Fitting the ceramic log set	
4.5 Spillage test	
5.0 TECHNICAL DETAILS GV60	Page 9
6.0 INSTRUCTIONS FOR MERTIK MAXITROL GV60 GAS CONTROL	Page 10
7.0 GAS TECHNICAL DATA	Page 11
8.0 TROUBLESHOOTING FLOW CHART MERTIK GV60	Page 12
9.0 PROBLEMS AND POSSIBLE SOLUTIONS	Page 15
APPENDIX 1 DIMENSIONAL DRAWINGS	Page 16
APPENDIX 2 PREPARATION AND INSTALLATION	Page 17
APPENDIX 3 CERAMIC LOG SET PLACEMENT	Page 18

1.0 USER INSTRUCTIONS - REMOTE CONTROL

1.1 General

- The unit is operated using a radio-controlled remote control. This consists of a manual transmitter and a receiver. The receiver is connected to the gas control block.
- The receiver and the gas control block are located behind the hinged panel on the front of the stove.
- If there is no change in flame height for a 6-hour period the appliance will turn down to standby mode.
- If the battery is low in receiver the systems shuts off the fire completely.
- When in use with 220V adapter and the power shuts off, the batteries will take over the power supply to let the receiver function normally.
- Designated low and high fire settings:
Double click the small flame button and the flame will be automatically go to low flame.
Double click the large flame button and the flame will be automatically go to high flame.
- Make sure the handset is switched off correctly to prevent battery drainage and loss of connectivity.

1.2 Manual transmitter

- The transmitter uses a radio-controlled signal, the signal code is set at the factory







1.3 Screen setup

- After the batteries have been inserted, press the **OFF** ● button and 🔥 (small) at the same time to toggle between °F (and 12 hour clock) and °C (and 24 hour clock).
- Wait a moment or press **OFF** ● to return to **MAN** mode.

1.4 Setting the time

- Press 🔥 (large) and 🔥 (small) at the same time to go to the **SET** mode or programming mode.
- The time can be set while the screen is flashing.
- Press 🔥 (large) to set the hour and minutes.
- Wait a moment or press **OFF** ● to return to **MAN** mode.

1.5 Setting the timer: P1 and P2 (THERMOSTAT VERSION ONLY)

- Briefly press the **SET** button to select the required mode  or .
- Keep the **SET** button pressed until the screen starts flashing.
- Then press 🔥 (large) or 🔥 (small) to set the required temperature.
- Wait a moment or briefly press the **OFF** ● button to select the **MAN** mode.
- If the temperature setting also needs to be switched off  (to reduce battery use),
- Turn  down until  appears on the screen.
- Once the temperatures have been set, the programme can be set by pressing the SET button. Programme  will appear. Keep the SET button pressed to set the time for the first on and off programme. Set the time you want the unit to switch on. Then press the SET button to switch the unit off.
- Press SET again for the  programme. Set the time you want the unit to switch on. Then press the SET button to switch the unit off.
- Press SET again to see the current programme on the display.



1.0 USER INSTRUCTIONS - REMOTE CONTROL

1.6 Igniting the flame (remote control)

- Open the gas shut-off cock that has been installed in the gas pipe to the unit.
- Press the "O I" switch on the gas control block to the "I" position.
- Turn the operating button on the gas control block into the ON position.
- Press the **OFF** ● and 🔥 (large) switches on the remote control at the same time. A short sound signal will confirm commencement. Short sound signals will then follow until the pilot light and main burner are ignited. Once the main burner is ignited, the flame will adjust to its maximum height automatically.

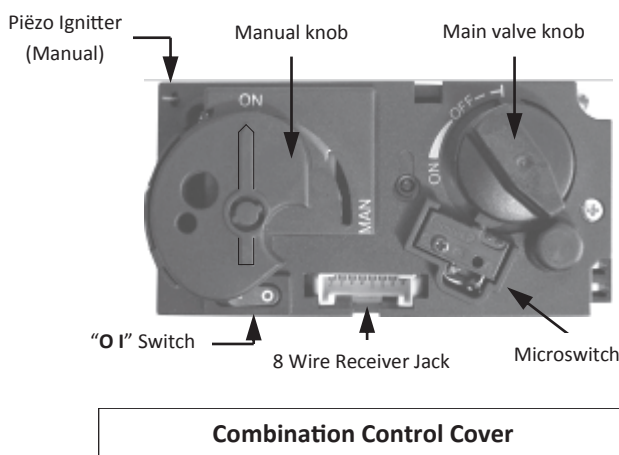

1.7 Possible error messages

- Long sound signals during ignition: Receiver batteries are almost empty. After this signal is heard, the unit may be switched on approximately 10x more times.
- 5 seconds of continuous sound signal: Error message. For example, one of the cables is not connected, the "O I" switch is not in the "I" position.
- 5x short sound signal: The pilot light or main burner are not ignited. Possible cause: air in the pilot pipes.

IMPORTANT: If the pilot light is extinguished, wait at least 5 minutes before repeating the steps above.

1.8 Setting the flame height / extinguishing the flame

- After the burner is ignited, the flame size will adjust to its maximum height automatically.
- Press the button 🔥 (small) on the image of the flame to reduce the height and to switch the burner off. (Extinguishing the flame: "**STAND BY**"). (Press the key for a short time to gradually reduce the flame.)
- Press the 🔥 (large) button to increase the flame height. (Press the button briefly to gradually increase the flame height).

1.9 Switching the unit off.

- Press the 🔥 (small) button to reduce the flame height and to switch the burner off ("**STAND BY**").
- Then press **OFF** ● to switch off the entire unit, including the pilot light.
- If the unit is out of use for a long period, set the "O I" switch on the gas control block to the "O" position to save the batteries.
- In this case, it is also recommended you close the gas shut-off cock in the supply line.

Breakdowns:

If the receiver is not receiving signals from the manual transmitter effectively, this could be caused by:

1. Flat batteries: replace the batteries.
2. An electronic problem: press "**RESET**" on the receiver.

Contact your fitter if the unit switches off regularly.

1.0 USER INSTRUCTIONS - REMOTE CONTROL

1.10 Inserting and replacing the batteries

The manual transmitter and receiver batteries have a life span of approximately one year. The use of alkaline batteries is recommended. The batteries need to be replaced when:

1. Manual transmitter: BATT appears on the display.
 2. Receiver: long sound signals can be heard during ignition.
1. Remote Control:
 - Open the small cover on the back.
 - Carefully remove the 9V square battery and remove the battery from the contact holder. Do not pull the wires!
 - Connect the new battery and place the whole unit back. Close the cover.
 2. Receiver:
 - Carefully remove the entire receiver from the holder.
 - Slide the small cover open.
 - Remove the batteries from the battery holder.
 - Place 4 new AA batteries in the battery holder. The spring must always be against the negative (-) pole of the battery.
 - Close the cover and place the receiver back into the holder.

If the batteries are not inserted correctly, the electronics of drive mechanism could be damaged irreparably.

Replace the batteries only when the unit is completely switched off.

IMPORTANT: Use only non-metallic tools to remove batteries. Removing batteries with a metal object may cause permanent damage to the electronic control.

2.0 USER INSTRUCTIONS - MANUAL CONTROL

The unit may be operated by hand if there is a defect in the remote control. To do so, the ignite (piezo) cable of the receiver must first be removed and carefully slid into the piezo connector on the gas control block.

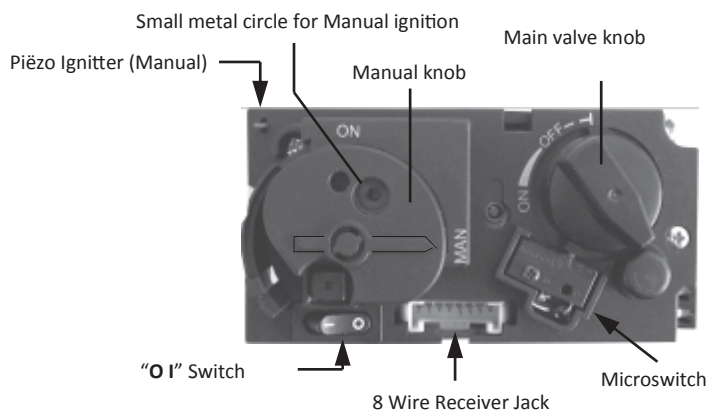

Combination Control Cover Manual position

2.1 Igniting the fire

- Open the gas shut-off cock that has been installed in the gas pipe to the unit.
- Press the "O I" switch, on the gas control block, to the "I" position.
- Turn the main valve knob, on the gas control block, completely to the right. The button will make a "click" sound.
- Turn the manual knob on the gas control block into the "MAN" position. A metal circle in the knob will become visible.
- Push the metal circle inwards using a small screwdriver or other instrument. Gas will now flow to the pilot flame.
- While keeping the metal circle pressed down, press the (square) piezo button (along the "O I" switch) several times to ignite the pilot flame. You will be able to see whether the pilot flame is burning through the glass window.
- If the pilot flame is alight, keep the metal circle pressed down for another 10 seconds and then let go.

IMPORTANT: If the pilot light is extinguished, wait at least 5 minutes before repeating the steps above.

- Turn the manual knob to the **ON** position. The burner may or may not ignite, depending on the position of the main valve knob.
- By turning the main valve knob to the required setting to the left, the burner will ignite and the flame size can be adjusted.

2.2 Extinguishing the fire

Turn the main valve knob, on the gas control block, completely to the right. The burner will turn off. The pilot flame continues to burn.

2.3 Switching the unit off

Press the "O I" switch, on the gas control block, to the "O" position. The pilot flame will extinguish.

If the fireplace is not used for an extended period of time, we recommend closing the gas shut-off cock in the supply line.

3.0 INSTALLATION INSTRUCTIONS

NOTE: The installation should only be performed by an authorized gas fitter.

3.1 General information

- The gas fireplace must be installed, connected and inspected by a Gas Safe registered engineer, according to British standards and current gas regulations. Failure to install the appliance correctly could lead to prosecution. **Read these instructions fully before beginning any installation work.**
- The flue system and the terminals must meet the requirements outlined in the manufacturer's instructions and in accordance with British Standards BS5440 parts 1 & 2.
- The chimney/fireplace that the appliance is installed with, whether existing or purpose built, must be made from non-combustible materials.
- The temperature of the walls and shelves near the side and back of the unit may not be more than 80°C higher than the temperature of the environment.
- The product needs to be serviced annually and inspected by a Gas Safe registered engineer.
- The instructions are only applicable if the relevant country code is stated on the unit. If this is not the case, the gas technical information for the relevant country needs to be consulted and modifications discussed with the manufacturer.
- There will be air in the gas pipes when the unit is first used. The gas pipes therefore need to be purged first.
- Ignite the fire according to operating instructions and check whether the burner flame is uniform. After the unit has been used for the first time, you should remove any deposits resulting from running/burning in the paint, using an appropriate glass cleaner.
- This appliance features an Oxypilot atmospheric sensing device. The Oxypilot will shut down the appliance if an unacceptable amount of harmful products of combustion accumulate. Under no circumstances should the Oxypilot be altered or bypassed in anyway. If after a period of use the appliance shuts down for no apparent reason, the consumer should be informed to stop using the appliance immediately until it has been fully checked.
- Normal adventitious ventilation should provide a suitable amount required for this appliance. If there are any forced ventilation systems adjacent to the installation (i.e. cooker extraction hoods) then additional ventilation may be required in accordance with national, regional and local standards and regulations.
- A fireguard complying with BS 8423 should be fitted for the protection of young children, the elderly or the infirm.
- The unit must be cleaned and inspected annually by a Gas Safe registered engineer.

Distance to combustible materials:

- Furniture, curtains etc. = 1200mm
- Flooring (without using a hearth) = 300mm
- Flooring (using a hearth with a minimum depth of 300mm) = 140mm

IMPORTANT: Gas fires become hot when they are in operation. After installing of the appliance the glass surface is considered an active zone. The glass surface can become very hot. **CARE SHOULD BE TAKEN** at all times with supervision of children and the infirm. Gas fires must not be on or placed against flammable materials (curtains etc.). Never install the unit against or within a flammable wall.

NOTE: Construction material for fireplaces and mantles etc. or built-in situation, must be made of non-combustible material. This also applies to floors and ceilings. Never use flammable materials near the unit in compliance with the above requirements. If in doubt, consult your dealer.

3.2 Chimney preparation

If the existing chimney was previously used for burning solid fuel, the flue must be swept clean prior to installation. A chimney draw of approximately 5 pascals is sufficient to run the appliance. If the chimney draft is greater than 20 pascals it is recommended that steps are taken to reduce the draft.

4.0 POSITIONING THE APPLIANCE

4.1 Installation of the flue liner

The chimney must be lined with a 100mm diameter stainless steel gas flue liner. Proprietary terminals must comply with BS715 or BS1289. Any terminal or termination must be positioned in accordance with BS5440 Part 1 to ensure that the products of combustion can be safely dispersed into the outside atmosphere. For decorative purposes, the gas flue liner may be sleeved with 125mm diameter vitreous enamelled flue pipe.

4.2 Connecting the gas lines

You can determine where the gas pipes will be placed depending on the positioning of the appliance. Ensure control equipment is not twisted during installation and there is no excessive tension. Accessibility of various connection points in relation to components need to be maintained. After installation, check the connections for gas leakage. Use a 3/8" gas tap in the main gas supply. **Ensure the gas pipes are dirt-and sand-free.** The gas connection should only be done without any excessive tension in the tubes etc. This prevents any damage occurring to the gas control equipment.

4.3 Preparation and installation (see Appendix 2 - page 21)

- Remove the packaging and check the unit for possible damage.
- Place the unit on a stable surface.
- Do not place the unit on its back or side!
- Place the unit near to the installation location.
- Lift the cast iron lid from the unit and carefully place aside. **(1)**
- Locate the four wing bolts on the rear face of the front cast iron panel and unscrew **(2 & 3)**. Carefully remove the cast iron front panel to gain access to the gas appliance - take care when removing as this component is heavy.
- Next, open the door of the gas appliance and take all the packaged components out— check to make sure they are not damaged or broken.
- Fit the ceramic log set (see section appendix 3 - page 22).
- Replace the cast iron front panel and secure with the four wing bolts.
- Replace the cast iron lid and position the unit at the installation location.
- Adjust the feet on unit to maintain a level installation.

4.4 Fitting the ceramic log set (see Appendix 3 - page 22)

- First place the ceramic log part on the burner as shown.
- Spread the "fusilli" (spiral-shaped ceramic material) around the ceramic log part and evenly over the burner so that the burner is just covered.
- Spread the glowing material (lava granules) and spread them over the burner plate.
- **Pay attention to the air supply.** Glowing embers can be placed here and there as decoration.
- Place the ceramic wood blocks in the correct order as shown on Appendix 4.
- Place the logs carefully. Incorrect placement can seriously affect the flames or cause a malfunction of the burn process (sooting).
- **Slot/opening between burner and mesh deco plate must be kept free of glowing material**
- Close the door.

IMPORTANT: Make sure the pilot light remains unobstructed.

4.5 Spillage test

The appliance must be fully installed before the spillage test is performed. For instructions on how to ignite the appliance please see sections 1 and 2 of this booklet.

- Close all doors and windows of the room in which the appliance is located.
- Ignite the main burner and operate on the highest setting.
- Use a smoke match and hold underneath the draught diverter (located at the rear of the appliance) at the position where the TTB sensor is located. If the smoke is drawn into draught diverter the test is successful. If it is not there is spillage and the appliance should not be used until this is rectified.

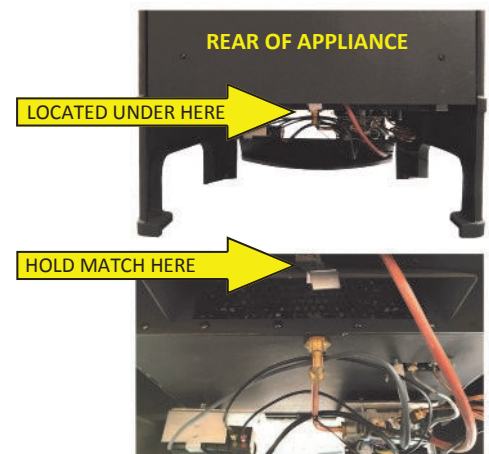

5.0 TECHNICAL DETAILS GV60

Gas valve type:	Mertik GV60
Ignition:	Remote control operation and Piezo ignition
Gas connection:	3/8 "(External)
Unit category:	B11BS
Pilot flame:	SIT 3 flames

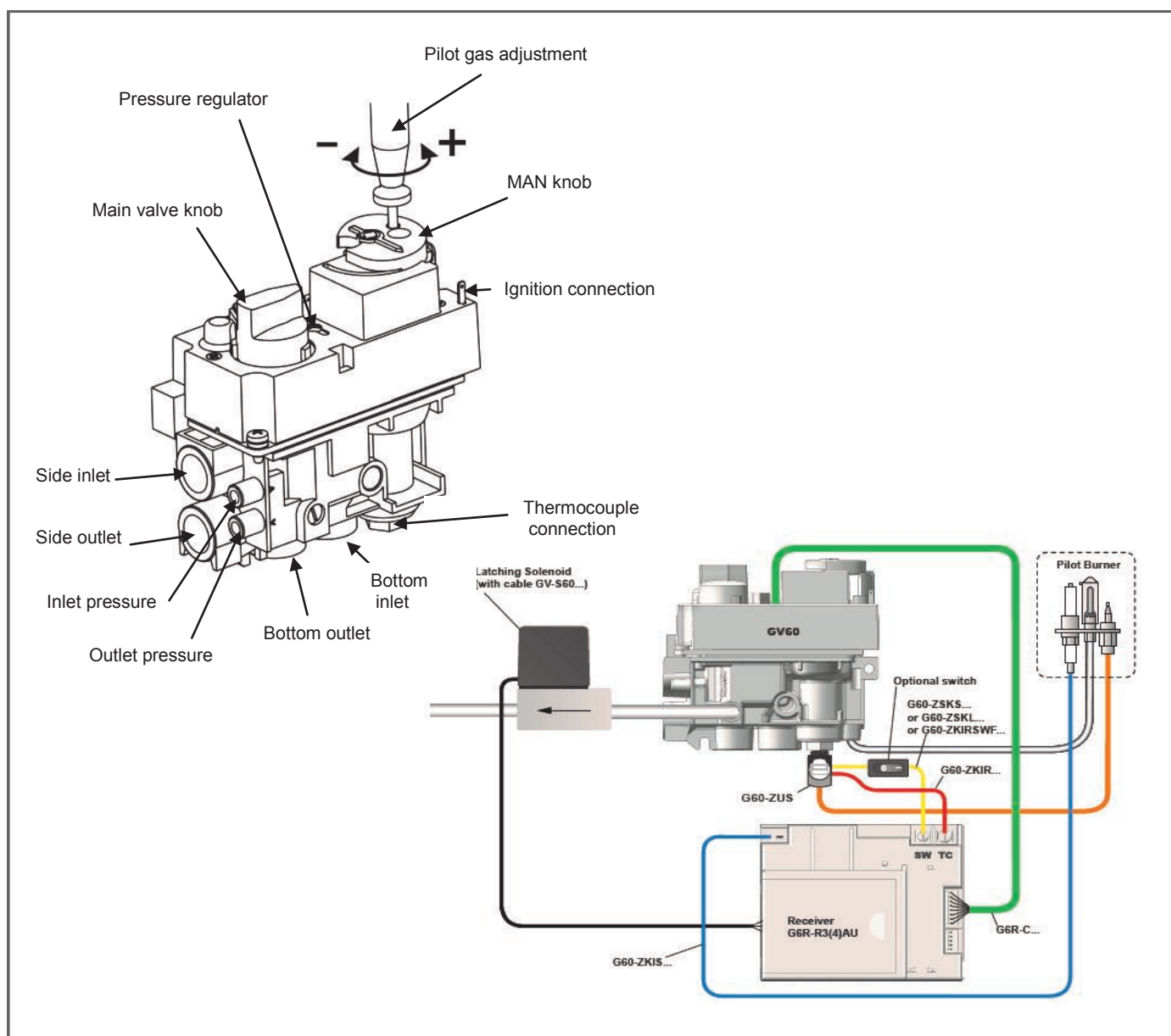

6.0 INSTRUCTIONS FOR MERTIK MAXITROL GV60 GAS CONTROL

IMPORTANT: Do not start up the unit if the window is not present or broken.

Ensure that the fuel supplied to the unit is clean and free from particles and moisture.

Before a gas supply pipe (new or existing) is connected to the main gas pipe at the gas meter and to the gas control block of the unit, clean and dry compressed air should be blown through it. Cut copper pipes as well as aluminium pilot pipes must be deburred and blown clean before they are connected. The dust filter at the connection to the gas control block will only filter out the coarsest dirt from the system. Fine particles are still able to reach the inside and may damage and/or adversely affect regulation in the gas control block.

Heat, moisture and dust are a threat to all electronic components.

Protect the electronic gas control *until* all construction, plastering and paintwork has been completed. If such work cannot be avoided, then protect the control against dirt and moisture penetration by using, for example plastic film.

IMPORTANT: Electronic components will become permanently faulty when exposed to temperatures higher than 60°C. Standard AA batteries will crack open at temperatures >54°C and the battery contents will damage the electronic switches located underneath. Batteries last longest at <25°C. At >50°C the life span is around 23 weeks, this makes the use of the gas fire unnecessarily expensive.

Only install the gas control block and receiver as pre-installed at the factory.

Remember that components may have to be replaced or that repairs may have to be performed at a later date. This may be more difficult if the control is installed using a method that is different from the instructions provided here.

Only place the batteries *after* wiring to the receiver, gas control block and pilot set is connected.

Premature connection to the energy source may damage the control's CPU (central processor).

Ensure that the ignition cable is not near the antenna wire and that they do not cross each other.

The high voltage released at ignition may damage the sensitive receiver circuit. This may mean that the unit becomes less responsive or not responsive at all to handset commands.

NOTE: Do not tighten the contact breaker and the thermocouple connection too tightly on the gas control block or to each other. It is sufficient to tighten by hand and add a half a turn with an open-end spanner. Tightening too much will break the connection to the magnetic coil below and/or the insulation around the aluminium contact pin in the contact breaker. This may lead to the magnetic coil not opening the gas supply to the pilot and the unit not working.

Prevent leakage of the ignition spark to other parts of the installation than the Ignition by the pilot.

Keep the ignition free of hull or other metal parts. If cable extension is used, see to it that connections are additionally insulated with a silicone grommet.

For automatic start via the transmitter, the receiver and the control the gas control valve should be switched.

The oval disk on the gas control block should be turned to the ON position. The **I/O** switch should be set to "I". The ignition must be connected to the receiver box at the terminal **SPARK**.

The transmitter's contains the thermostat sensor system.

The transmitter operates best at 2 to 3m from the unit. Although the communication via short wave radio signals takes place, it is recommended that the transmitter in the 'visibility' of to lay the gas apparatus in a place where the user wants to experience a pleasant temperature. Place the hand transmitter in direct sunlight or other hot places. The thermostat measures the temperature and regulates the flame size of the gas in accordance.

Remove batteries only with the red ribbon which is under the battery, not with a metal tool.

Removing batteries with a metal object can permanently damage the electronic control.

7.0 GAS TECHNICAL DATA

CATEGORY		I2L	I2ELL	I2H	I2E+	I3P	I3+/I3B/P	I2E
GAS TYPE		G25	G25	G20/25	G20/25	G31	G30/31	G20/25
PREPRESSURE	MBAR	25	20	20	20	30/37/50	28-30/37/50	20
BURNERPRESSURE	MBAR	15.53	12.45	10.65	10.65	29.5/36/36	27-29/36/36	10.65
INJECTOR SIZE	∅	2.2	2.2	2.2	2.2	1.3	1.3	2.2
INPUT HI	KW	6.18	5.55	6.23	6.23	6.26	6.26	6.23
INPUT	KW	6.86	6.16	6.9	6.9	6.8	6.78	6.9
CONSUMPTION	m ³	0.759	0.68	0.658	0.658	0.245	0.19/0.247	0.658

NOTE: Wait three minutes between each starting attempt.

Appliance has NoX Class 5

AT I2H, I3B/P	BE I2E+, I3+	DK I2H, I3B/P	DE I2ELL, I3B/P
FI I2H, I3B/P	FR I2E+, I3+	GR I2H, I3B/P	GB I2H, I3+
IS I3B/P	IE I2H, I3+	IT I2H, I3+	LU I2E, I3B/P
NL I2L, I3B/P	NO I3B/P	PT I2H, I3+	ES I2H, I3+
SE I2H, I3B/P	CY I3B/P, I3+	EE I2H, I3B/P	LT I2H, I3B/P
LV I2H, I3B/P	MT I3B/P	HU I2H, I3B/P	PL I3B/P
SI I2H, I3B/P	SK I2H	TR I2H, I3B/P	

Name	Thermocet Int.B.V. Nederland
Type/model	CLASSIC FIRE VEGA C7 S AB
Gastype	G20
Gas supply pressure	G20-20 Mbar
Appliance type	C11/C31/C91
Energy efficiency Class	D
Heat input (Hi) in kW	6,2
Heat output in kW	4,6
Efficiency in %	74,5
Efficiency EEI in %	74,5

G20

D

Name	Thermocet Int.B.V. Nederland
Type/model	CLASSIC FIRE VEGA C7 S AB
Gastype	G30/31
Gas supply pressure	G30/31-30 Mbar
Appliance type	C11/C31/C91
Energy efficiency Class	D
Heat input (Hi) in kW	5,8
Heat output in kW	4,3
Efficiency in %	74,5
Efficiency EEI in %	74,5

G30/31

D

8.0 TROUBLESHOOTING FLOW CHART - MERTIK GV60

No.	ACTION		POSSIBLE PROBLEM/CAUSE	SOLUTION	
1.	Remote Control START: press both buttons to start ignition sequence. Beep will occur each second.	NO →	Remote control battery low.	Replace battery, 1x 9V quality alkaline.	
			Receiver batteries, located beneath appliance, low.	Replace batteries, 4x AA quality alkaline.	
			Optional mains adapter not operating properly.	Check mains adapter.	
			Check coding of remote control and receiver.	Learn in new code, see instructions and label on receiver.	
			Remote control/receiver range limited.	1. Move antenna cable, see instructions. 2. Replace receiver.	
			Optional wall switch / cabling not operating properly.	Replace wall switch / cabling.	
			Receiver fuse blown (in older versions only).	Replace receiver.	
	OK ↓				
	Optional wall switch START: press ON button > wall switch works.	NO →	Bent pin on switch, or cable not operating properly.	Straighten pin, replace wall switch or cable.	
2.	Magnet unit in gas valve is energised (audible click)	NO →	No beep	Impulse magnet not operating properly.	Replace gas valve.
			3 short beeps	Receiver batteries low.	Replace batteries in receiver, 4x AA quality alkaline.
			1 long beep	ON/OFF switch on gas valve in OFF position.	Set switch to ON.
				8-wire cable between receiver and gas valve defective / poor contact.	Check cable, especially in case of plug connection.
			Switch cable disconnected.	Check switch cable, see fig. 1 on page 18	
			Motor not operating properly.	Replace gas valve.	
Micro switch on gas valve not operating properly.	Replace gas valve.				
	OK ↓				

8.0 TROUBLESHOOTING FLOW CHART - MERTIK GV60

No	ACTION	POSSIBLE PROBLEM/CAUSE	SOLUTION
3.	<p>Continuous spark</p> <p>Spark will occur each second.</p>	NO →	<p>Ignition components not operating properly.</p> <p>Check connection between cable & IGN electrode.</p> <p>Check IGN electrode spark gap.</p> <p>Check IGN electrode for discharge to ground (break in ceramic).</p> <p>Check IGN cable for damage</p> <p>Increase distance between IGN cable and all metal parts. Check that spark does not discharge to ground at location of spark plug connection. Shorten cable if possible. If applicable, provide extra insulation with silicon hose etc.</p>
		NO →	<p>IGN sequence stops, no pilot flame. No reaction to transmitter command (receiver does not react).</p> <p>Press RESET button, see instructions.</p> <p>Add ground wire between pilot burner and gas valve.</p> <p>Do not coil the IGN cable.</p> <p>Shorten IGN cable if possible.</p>
		NO →	<p>IGN sequence stops, no pilot flame. Transmitter command is possible.</p> <p>IGN sequence stops, no pilot flame. Transmitter command is possible.</p>
4.	Pilot lit.	NO →	<p>TC and SW cable reversed.</p> <p>Check connection of cable to receiver and interrupter, see fig. 1.</p> <p>Impulse magnet not operating properly.</p> <p>Replace gas valve.</p> <p>Short between interrupter and SW cable.</p> <p>Check connection to interrupter.</p> <p>No gas magnet unit drops after 30 second audible count).</p> <p>Check gas supply to gas valve.</p>
5.	Sparkling stops after pilot is lit	NO →	<p>Short between interrupter and TC cable.</p> <p>Check connection to interrupter, see fig. 1</p> <p>Electronic measuring amplifier defective.</p> <p>Replace receiver.</p>

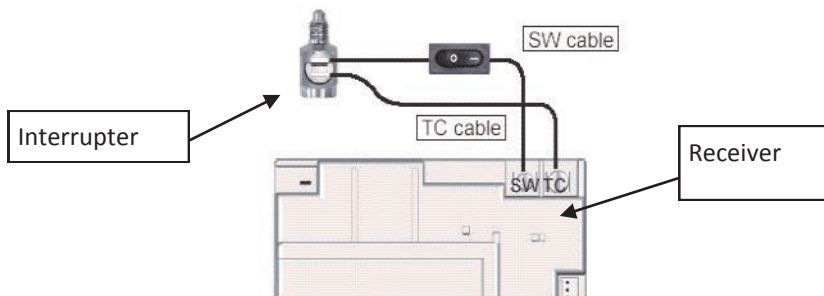

Figure 1

8.0 TROUBLESHOOTING FLOW CHART - MERTIK GV60

No	ACTION		POSSIBLE PROBLEM/ CAUSE	SOLUTION
6.	Motor turns to main gas and pilot stays lit.	NO → Solenoid drops (audible click)	Resistance in thermo current circuit too high.	Check cables and connections in thermo current circuit.
			Not enough heat on thermocouple.	Check position of pilot to thermocouple and intensity of pilot flame.
			Low voltage from thermocouple.	Check connections and, if necessary, replace thermocouple. Do not over tighten the connections!
			Short because thermocouple end is damaged.	Replace thermocouple, do not overtighten the connections!
OK ↓	Main burner is lit.	NO →	IGN sequence stops. No reaction to transmitter command (receiver does not react).	Press RESET button, see instructions.
				Add ground wire between pilot burner and gas valve.
				Do not coil the IGN cable. Shorten IGN cable if possible.
OK ↓	Main burner stays lit.	NO →	Gas valve manual knob in "MAN" position.	Turn knob to "ON" position.
OK ↓	Main burner stays lit.	NO →	Too much / too little air flow / draft at pilot, blows out or is smothered.	Check whether restriction plate has been correctly applied in unit, see instructions. Poor flue location, check correctness of layout and connections.
OK ↓	Magnet unit drops while motor turns. 3 beeps.	NO →	Receiver batteries low.	Replace batteries, 1.5V AA quality alkaline!
YES ↓ OK	System can be switched OFF via remote control.	NO →	System can be switched OFF via ON/OFF switch.	Short between TC and SW cable. Check connection to interrupter block.
			YES ↓ OK	Replace gas valve.

9.0 PROBLEMS AND POSSIBLE SOLUTIONS

NOTE: Please first check if all guidelines were followed before attempting to solve any problems with the unit.

IMPORTANT: Solving problems with your unit, whether gas related or electrical, must always be performed by a qualified technician.

SYMPTOM	ACTION TO BE TAKEN
The pilot flame will not light after repeated ignition.	<ol style="list-style-type: none"> 1. There is air in the pipes if you switch the unit on for the first time or after a service. It will take a little while until all the air has flowed out of the pipes and gas flows through that can be ignited. Take it away and try to switch the pilot flame on several times in order to allow the air to escape. 2. See whether the gas pipe to the unit is open and if there is sufficient gas pressure to the unit. 3. Check whether there are sparks between the spark electrode and the pilot. If there are no sparks: <ol style="list-style-type: none"> a) Check whether the connection between the electrode and the ignition is broken or faulty. b) Check whether the spark short circuits at another point or jumps. c) Check whether the electrode is broken.
The pilot flame will not remain alight after ignition.	<ol style="list-style-type: none"> 1. Check whether the pilot flame is large enough to burn around the thermocouple. If the flame is too small, you need to check the gas feed pressure. If the size of the pilot flame cannot be adjusted, there may be an obstruction in the pilot. 2. Check whether the thermocouple interrupter is connected to the gas valve properly. 3. Check that the gas valve is not faulty.
The main burner goes out when the unit is warm.	<ol style="list-style-type: none"> 1. This can be a normal effect of the thermostat. Check whether the pilot flame is able to heat the thermocouple adequately. If the pilot flame is too small then the gas pipe or the pilot flame adjustment need to be checked.
Sharp blue flames that are released by the burner or a pilot that burns too wildly.	<ol style="list-style-type: none"> 1. Check whether the restriction plate has been used.
Weak (stifling) pilot flame.	<ol style="list-style-type: none"> 1. Check the pilot burner pressure.
Main burner will not burn after the pilot burner is functioning.	<ol style="list-style-type: none"> 1. Check if the motor button turns and whether the batteries are empty. 2. Possible defect in the gas block. 3. Check whether the pilot flame ignites the burner well. 4. Check that the burner opening is not blocked.

APPENDIX 1 - DIMENSIONAL DRAWINGS

PRODUCT DIMENSIONS

FLUE DIAMETER: 100mm GAS LINER / 125MM DECORATIVE SLEEVE PIPE

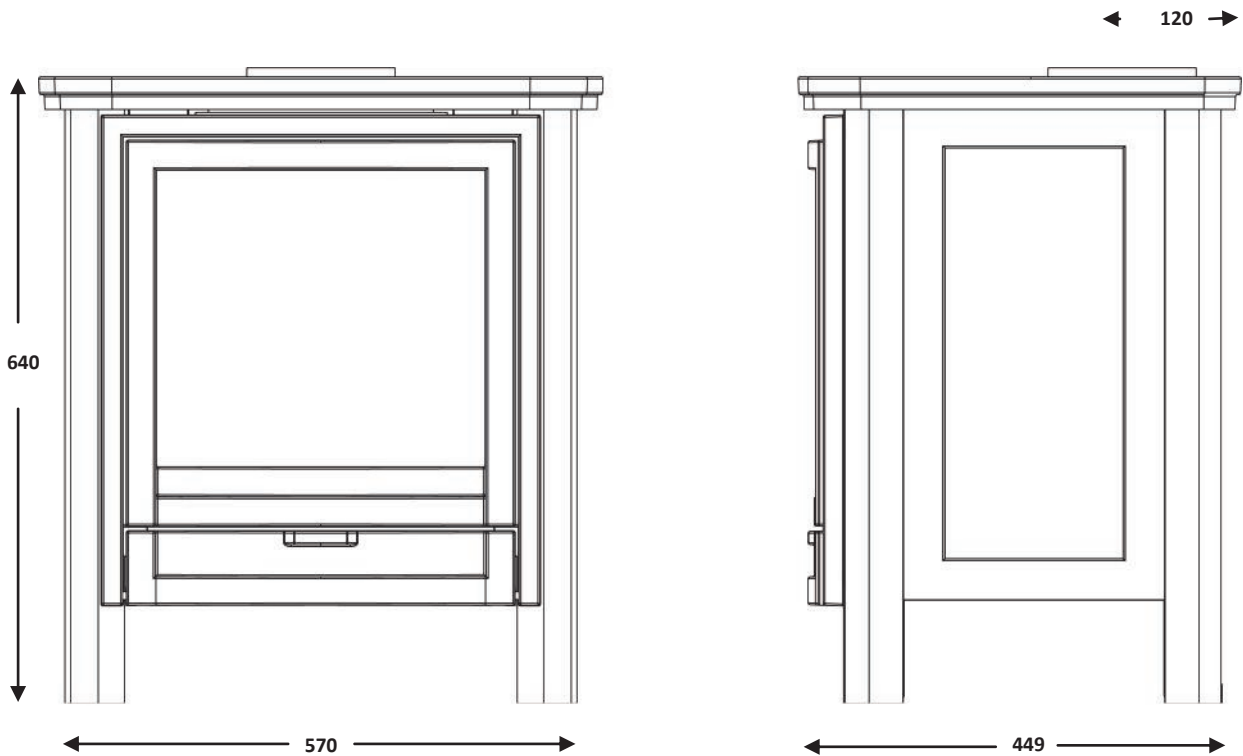

INSTALLATION DIMENSIONS

The stove must be located at least 280mm from any combustible materials. A combustible shelf may be fitted over the appliance: up to a depth of 150mm there must be a minimum 280mm clearance above the top of the stove. An increase in shelf depth requires an equal increase in clearance; i.e. a shelf depth of 200mm would require a clearance of 330mm.

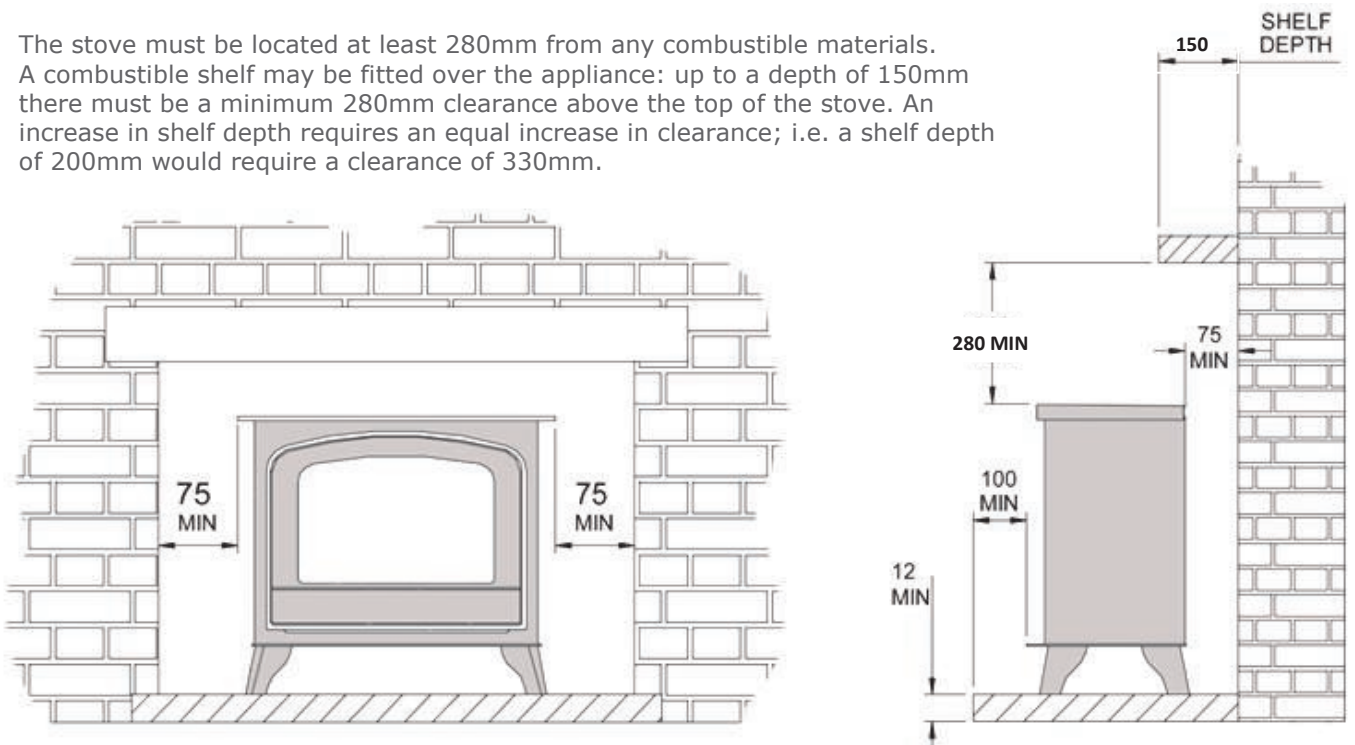

APPENDIX 2 - PREPARATION AND INSTALLATION

Images are for illustrative purposes only. Actual product may differ in appearance but all relevant technical aspects remain the same.

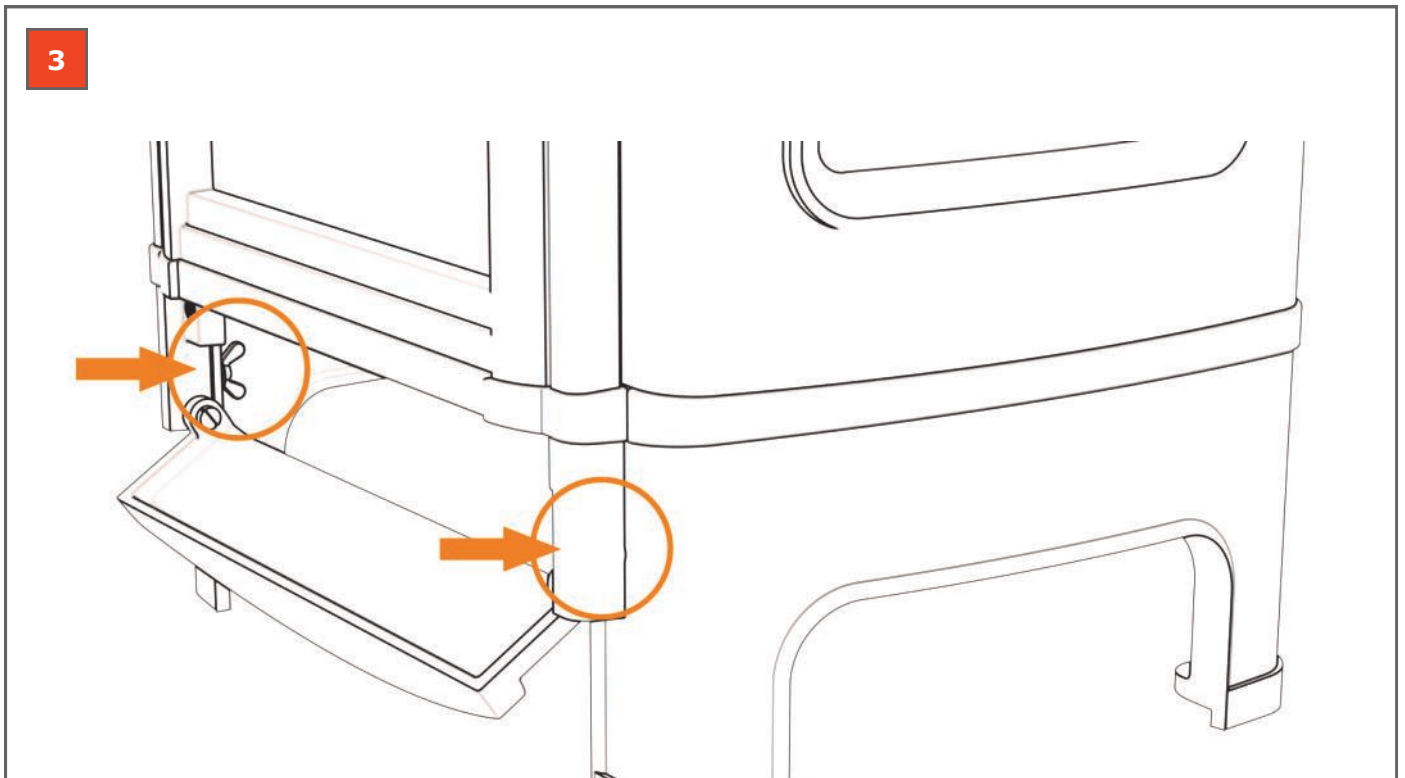
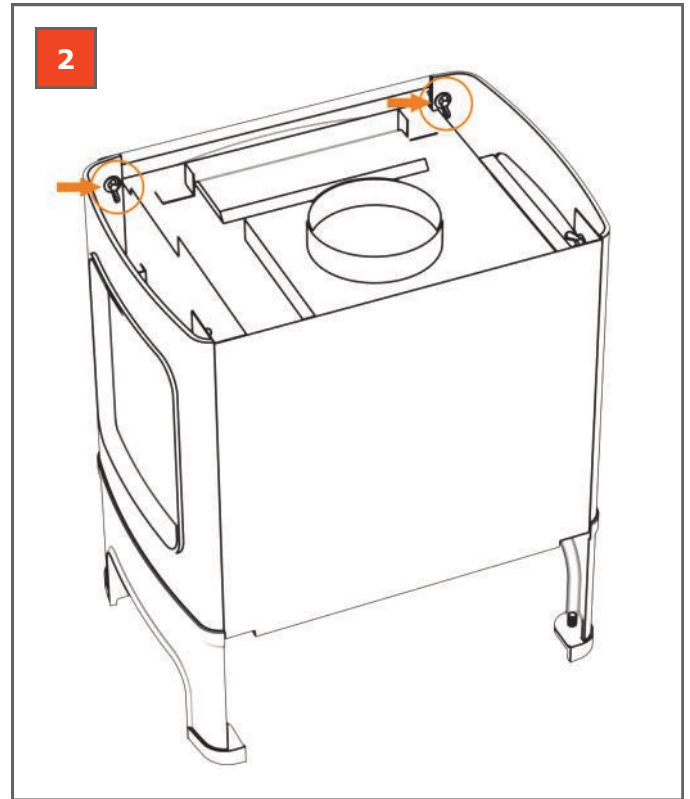
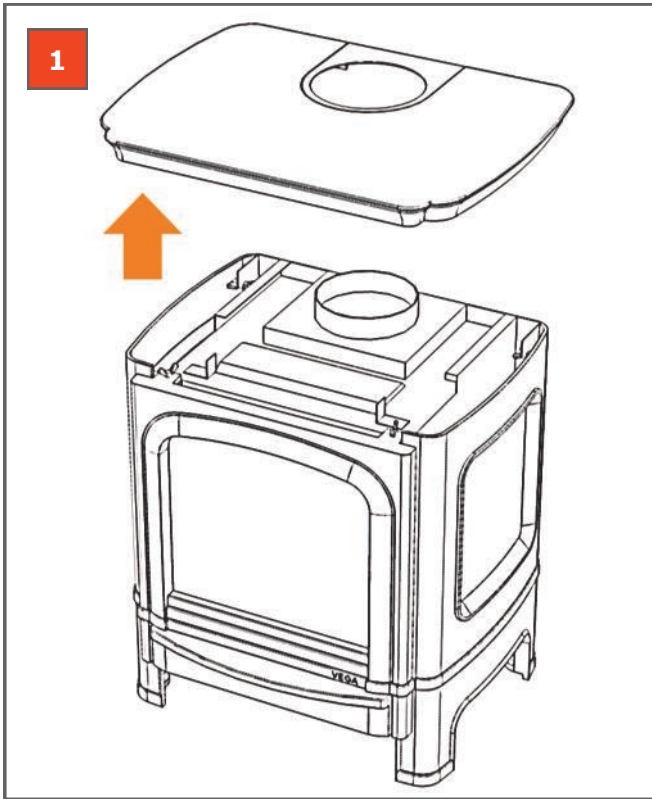

NOTE: Some models may feature hexagonal nuts instead of wingnuts. In this scenario a suitable socket wrench or spanner can be used to tighten/loosen them.

APPENDIX 3 - CERAMIC LOG SET PLACEMENT

NOTE: When installing the log set and the various glowing materials and accessories, the following must be taken into account:

- 1: No glowing material should be placed on or near the pilot burner.
- 2: Ensure that no ceramic material can fall on to the glass seals as this can damage the glass.
- 3: The slot/opening between the burner and the decorative mesh plate must be kept free of glowing material.
- 4: Do not use too much glowing material as this may affect the combustion process. Surplus material may be stored.

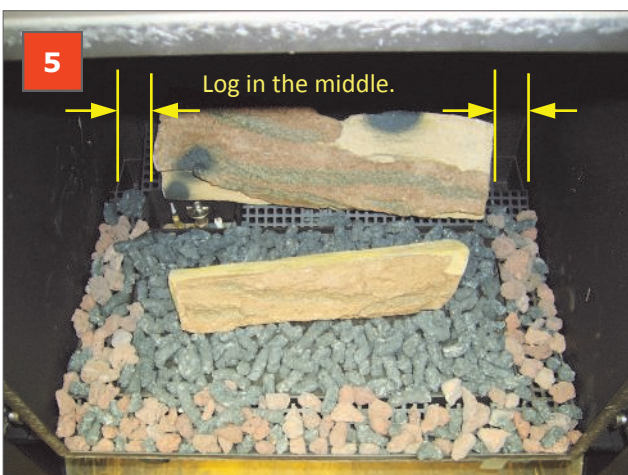
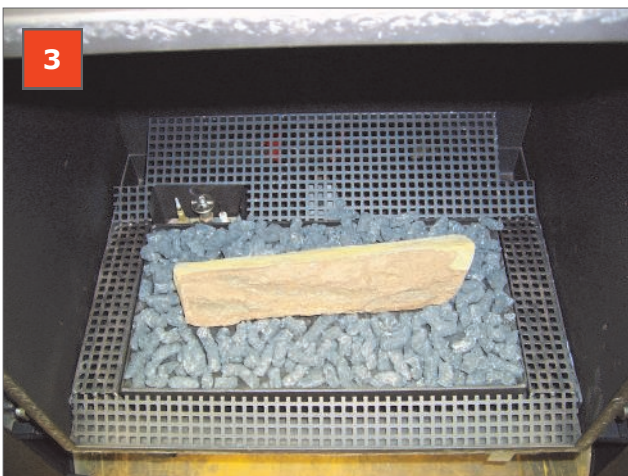
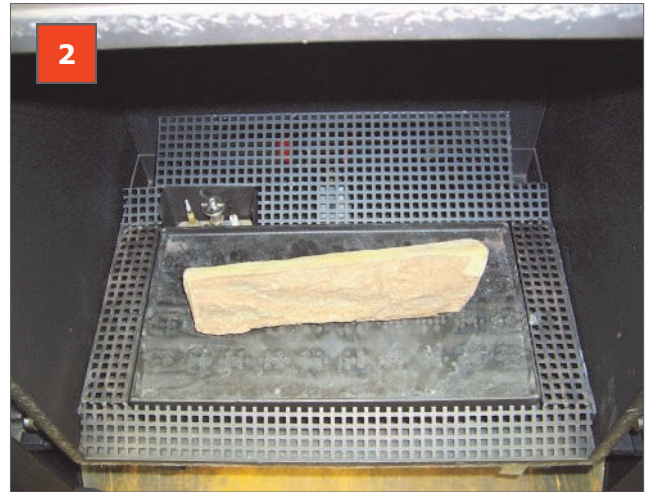

APPENDIX 3 - CERAMIC LOG SET PLACEMENT



Brought to you by



Imperial Point
Express Trading Estate
Stone Hill Road
Farnworth
Bolton
BL4 9TN

Tel: 01204 868 550 Fax: 01204 868 551 Email: sales@percydoughty.com

www.thegallerycollection.co.uk